

Compact vertical mast



- Working height: 5.70 m
- Compact dimensions
- Weight: 776 kg
- Usable indoors or outdoors

60 V



Capacity :

Indoor use227 kg including 2 people
Outdoor useincluding 1 people



Working height5.70 m
Platform height3.70 m



① **Overall length**1.36 m
 ② **Overall width**0.76 m
 ③ **Folded height**1.70 m
Basket internal dimensions:
 width x length0.74 m x 1.04 m
Ground clearance7.6 cm
 ④ **Turning radius (inside)**0.37 m
 ⑤ **Turning radius (outside)**1.40 m



Battery24 V/220 Ah
Built-in charger90 V to 240 V



Travelling speed3.65 km/h
Working speed1.0 km/h



Gradability25%



Tyresnot marking
 Drive wheels2 (front)
 Steering wheels2 (front)



Weight776 kg

Standard equipment:

- Proportional controls
- Travel at maximum height possible
- Descent and slope alarm
- 25A automatic charger built in
- Emergency lower controls on base
- Non marking tyres
- Crane lifting point
- **Anti-roll bar and parking brake**
- **Selectable motion alarm**

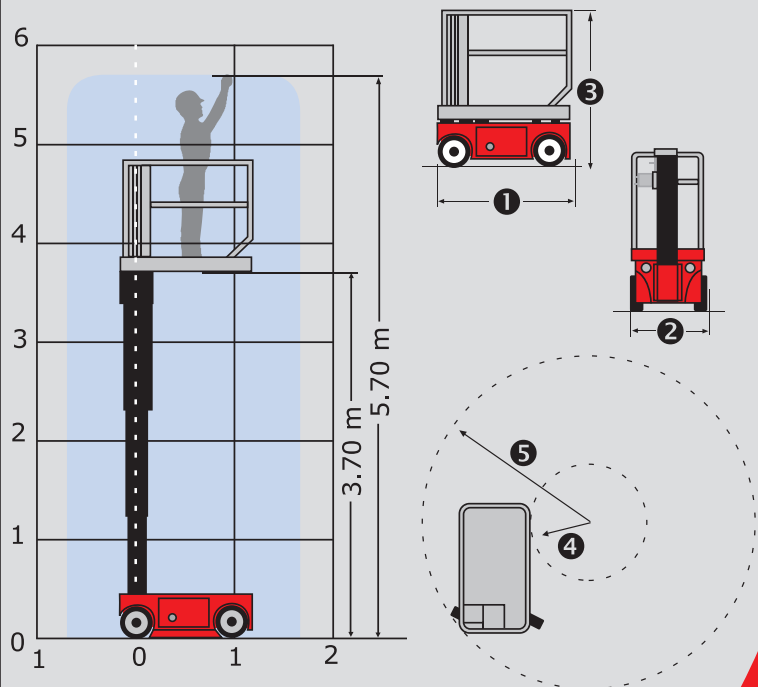

The specifications given are not binding to the manufacturer and can be modified without prior notification.
 The equipment shown in this leaflet may be standard, optional or unavailable depending on the version. For further details, please contact your MANITOU dealer.
 Complies with the machine directive (98-37-CE) and standards in the countries where the machine is delivered.

MANITOU BF SA

B.P. 249 - 44158 Ancenis Cedex - France
 Tel. : 33 2 40 09 10 11 / Export Department Fax : 33 2 40 09 10 97
 www.manitou.com

700415EN-A - 03/08

