

Operation Instruction

Crane Jib TJCL45

Function and Application:

The Crane Jib FJCS45 is a full-featured jib, is widely used in carrying or high stacking, such as docks, cargo shed, etc.

Design Features:

Can be adjusted to different angles and extension length of lifting

Use the chain to connect safely with the forklift

Crane jib set directly in the forks

Galvanized surface or spray-painted

Supplied with hook and shackle

Detailed parameter:

	Crane Height	Extension Length	Combined Length	Unit Weight
Crane Jib TJCS45	2230mm	3530mm	2100mm	190.0Kg



Position	Extension (mm)	SWL (Kg)
1	770	4500
2	2010	1100
3	2390	630
4	2770	470
5	3150	300
6	3530	150

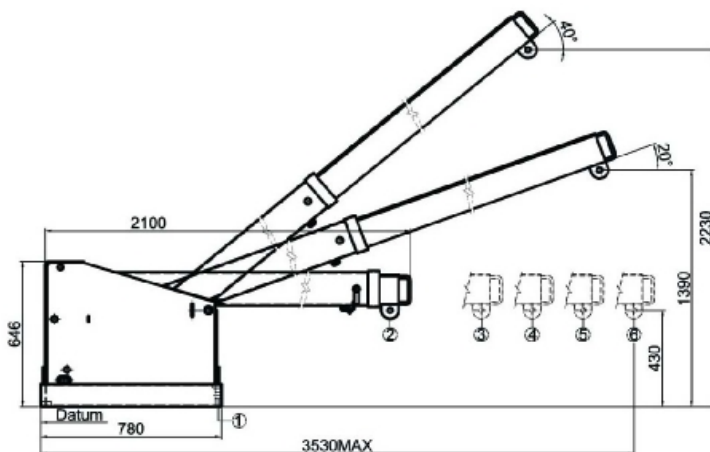

Attentions:

Prohibit people from standing under the weight or crane jib during craning and carrying, so as to avoid casualties.