

# Genie®



## Operator's Manual

*with Maintenance Information*

Second Edition  
Fifth Printing  
Part No. 43648

**S™-60**

**S™-65**

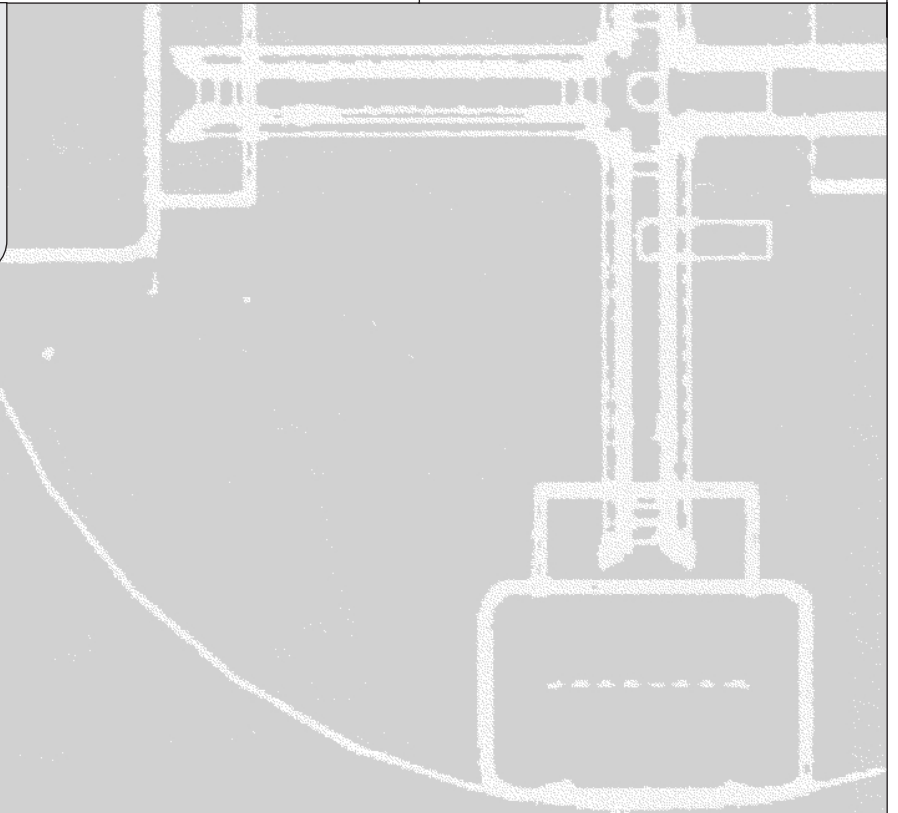

# Genie® S-60

# Genie® S-65

## Important

Read, understand and obey these safety rules and operating instructions before operating this machine. Only trained and authorized personnel shall be permitted to operate this machine. This manual should be considered a permanent part of your machine and should remain with the machine at all times. If you have any questions, call Genie Industries.

## Contents

	Page
Safety Rules .....	1
Controls .....	7
Pre-operation Inspection .....	10
Maintenance .....	12
Function Tests .....	16
Work Place Inspection .....	21
Operating Instructions .....	22
Transport .....	25
Decals .....	26
Specifications .....	28

## Contact us:

Internet: <http://www.genielift.com>  
e-mail: [techpub@genieind.com](mailto:techpub@genieind.com)

## Genie Industries

Copyright © 1995 by Genie Industries

First Edition: First Printing, January 1995  
Second Printing, January 1996  
Third Printing, October 1996

Second Edition: First Printing, November 1996  
Second Printing, March 1997  
Third Printing, March 1998  
Fourth Printing, February 2000  
Fifth Printing, July 2000

"Genie" is a registered trademark of Genie Industries in the U.S.A. and many other countries. "S" is a trademark of Genie Industries.

These machines comply with ANSI/SIA 92.5-1992.

♻️ Printed on recycled paper

Printed in U.S.A.

---

# Safety Rules



---

## Danger

Failure to obey the instructions and safety rules in this manual will result in death or serious injury.

---

## Do Not Operate Unless:

- You learn and practice the principles of safe machine operation contained in this operator's manual.

### 1 Avoid hazardous situations.

**Know and understand the above principle before going on to the next section.**

2 Always perform a pre-operation inspection.

3 Always perform function tests prior to use.

4 Inspect the work place.

5 Only use the machine as it was intended.

- You read, understand and obey:

Manufacturer's instructions and safety rules—safety and operator's manuals and machine decals

employer's safety rules and worksite regulations

applicable governmental regulations

- You** are properly trained to safely operate the machine.

SAFETY RULES

### Electrocution Hazards

This machine is **not** electrically insulated and will **not** provide protection from contact with or proximity to electrical current.

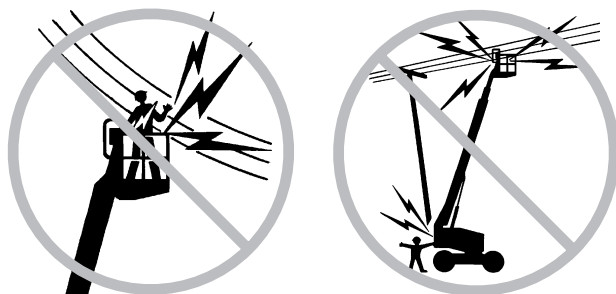

Maintain safe distances from electrical power lines and apparatus in accordance with applicable governmental regulations and the following chart.

Voltage Phase to Phase	Minimum Safe Approach Distance	
	Feet	Meters
0 to 300V	Avoid Contact	
300V to 50KV	10	3.05
50KV to 200KV	15	4.60
200KV to 350KV	20	6.10
350KV to 500KV	25	7.62
500KV to 750KV	35	10.67
750KV to 1000KV	45	13.72

Allow for platform movement, electrical line sway or sag and beware of strong or gusty winds.

Keep away from the machine if it contacts energized power lines. Personnel on the ground or in the platform must not touch or operate the machine until energized power lines are shut off.

Do not operate the machine during lightning or storms.

Do not use the machine as a ground for welding.

### Tip-over Hazards

Occupants and equipment shall not exceed the maximum platform capacity.

<b>Maximum platform capacity S-65</b>	500 lbs	227 kg
<b>Maximum platform capacity S-60 with 8 Ft Platform</b>	500 lbs	227 kg
<b>Maximum platform capacity S-60 with 6 Ft Platform</b>	600 lbs	272 kg
<b>Maximum platform capacity S-60 with 6 Ft Platform with foam-filled tires and proper counterweight configuration</b>	750 lbs	340 kg
<b>Maximum occupants</b>	2	

**SAFETY RULES**

Do not raise or extend the boom unless the machine is on a firm, level surface.

Do not depend on the tilt alarm as a level indicator.

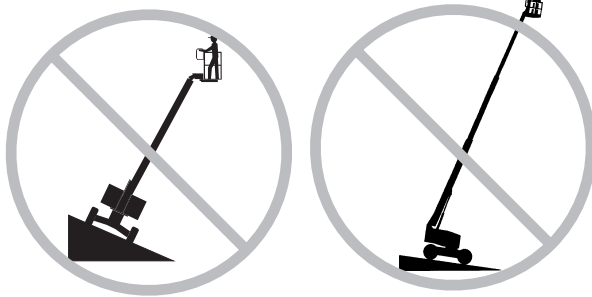

The tilt alarm sounds in the platform only when the machine is on a severe slope.

If the tilt alarm sounds:

Do not extend, rotate or raise the boom above horizontal. Move the machine to a firm, level surface before raising the platform. If the tilt alarm sounds when the platform is raised, use extreme caution to retract the boom and lower the platform. Do not rotate the boom while lowering. Move the machine to a firm, level surface before raising the platform.

Do not operate the machine in strong or gusty winds. Do not increase the surface area of the platform or the load. Increasing the area exposed to the wind will decrease machine stability.



Use extreme care and slow speeds while driving the machine in the stowed position across uneven terrain, debris, unstable or slippery surfaces and near holes and drop-offs.

Do not drive the machine on or near uneven terrain, unstable surfaces or other hazardous conditions with the boom raised or extended.

Do not push off or pull toward any object outside of the platform.



---

**Maximum allowable side force - ANSI & CSA**

150 lbs  
667 N

---

**Maximum allowable manual force - CE**

90 lbs  
400 N

---

Do not alter or disable machine components that in any way affect safety and stability.

Do not replace items critical to machine stability with items of different weight or specification.

Do not modify or alter an aerial work platform. Mounting attachments for holding tools or other materials onto the platform, toeboards or guard rail system can increase the weight in the platform and the surface area of the platform or the load.

## SAFETY RULES

Do not place or attach overhanging loads to any part of this machine.

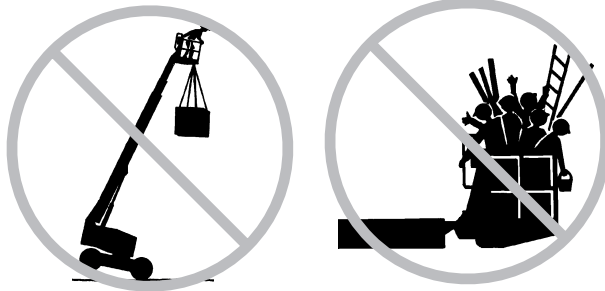

Do not place ladders or scaffolds in platform or against any part of this machine.

Do not use the machine on a moving or mobile surface or vehicle.

Be sure all tires are in good condition, air-filled tires are properly inflated and lug nuts are properly tightened.

**Models with 750 lb (340 kg) Capacity:** Do not use air-filled tires. Models are equipped with foam-filled tires. The wheel weight and the proper counterweight configuration are critical for machine stability.

Do not use the platform controls to free a platform that is caught, snagged or otherwise prevented from normal motion by an adjacent structure. All personnel must be removed from the platform before attempting to free the platform using the ground controls.

## Fall Hazards



Occupants must wear a safety belt or harness in accordance with governmental regulations. Attach lanyard to anchor provided in platform.

Do not sit, stand or climb on the platform guard rails. Maintain a firm footing on the platform floor at all times.

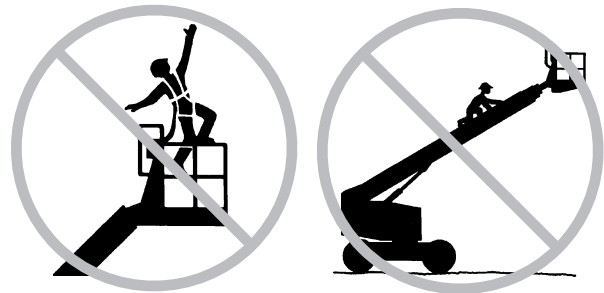

Do not climb down from the platform when raised.

Keep the platform floor clear of debris.

Lower the platform entry mid-rail or close the entry gate before operating.

## Bodily Injury Hazard

Do not operate the machine with a hydraulic oil or air leak. An air leak or hydraulic leak can penetrate and/or burn skin.

Always operate the machine in a well-ventilated area to avoid carbon monoxide poisoning.

**SAFETY RULES**

**Collision Hazards**

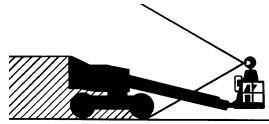

Be aware of limited sight distance and blind spots when driving or operating.

Be aware of boom position and tailswing when rotating the turntable.

Check work area for overhead obstructions or other possible hazards.

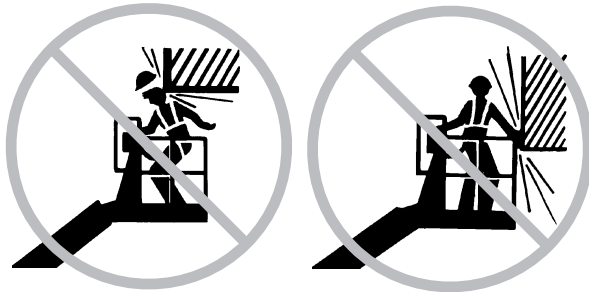

Be aware of crushing hazard when grasping the platform guard rail.

It is recommended that operators wear an approved hard hat when operating the machine.

Observe and use color-coded direction arrows on the platform controls and drive chassis for drive and steer functions.

Do not lower the boom unless the area below is clear of personnel and obstructions.

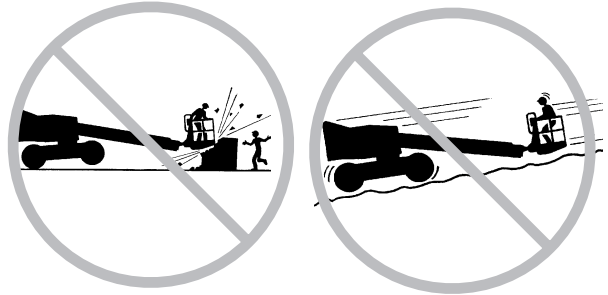

Limit travel speed according to condition of ground surface, congestion, slope, location of personnel, and any other factors which may cause collision.

Do not operate a boom in the path of any crane unless the controls of the crane have been locked out and/or precautions have been taken to prevent any potential collision.

No stunt driving or horseplay while operating a machine.

**Component Damage Hazards**

Do not use any battery or charger greater than 12V to jump-start the engine.

Do not use the machine as a ground for welding.

Be sure the hydraulic shutoff valves (located by hydraulic tank) are open before starting engine.

## SAFETY RULES

**Explosion and Fire Hazards**

Do not start the engine if you smell or detect liquid petroleum gas (LPG), gasoline, diesel fuel or other explosive substances.

Do not refuel the machine with the engine running.

Refuel the machine and charge the battery only in an open, well-ventilated area away from sparks, flames and lighted tobacco.

Do not operate the machine in hazardous locations or locations where potentially flammable or explosive gases or particles may be present.

**Damaged Machine Hazards**

Do not use a damaged or malfunctioning machine.

Conduct a thorough pre-operation inspection of the machine and test all functions before each work shift. Immediately tag and remove from service a damaged or malfunctioning machine.

Be sure all maintenance has been performed as specified in this manual and the *Genie S-60 & Genie S-65 Service Manual*.

Be sure all decals are in place and legible.

Be sure the operator's, safety and responsibilities manuals are complete, legible and in the storage container located on the platform.

**Decal Legend**

Genie product decals use symbols, color coding and signal words to identify the following:



Safety alert symbol—used to alert personnel to potential personal injury hazards. Obey all safety messages that follow this symbol to avoid possible injury or death.

**▲ DANGER**

Red—used to indicate the presence of an imminently hazardous situation which, if not avoided, will result in death or serious injury.

**▲ WARNING**

Orange—used to indicate the presence of a potentially hazardous situation which, if not avoided, could result in death or serious injury.

**▲ CAUTION**

Yellow with safety alert symbol—used to indicate the presence of a potentially hazardous situation which, if not avoided, may cause minor or moderate injury.

**CAUTION**

Yellow without safety alert symbol—used to indicate the presence of a potentially hazardous situation which, if not avoided, may result in property damage.

**NOTICE**

Green—used to indicate operation or maintenance information.



# Controls

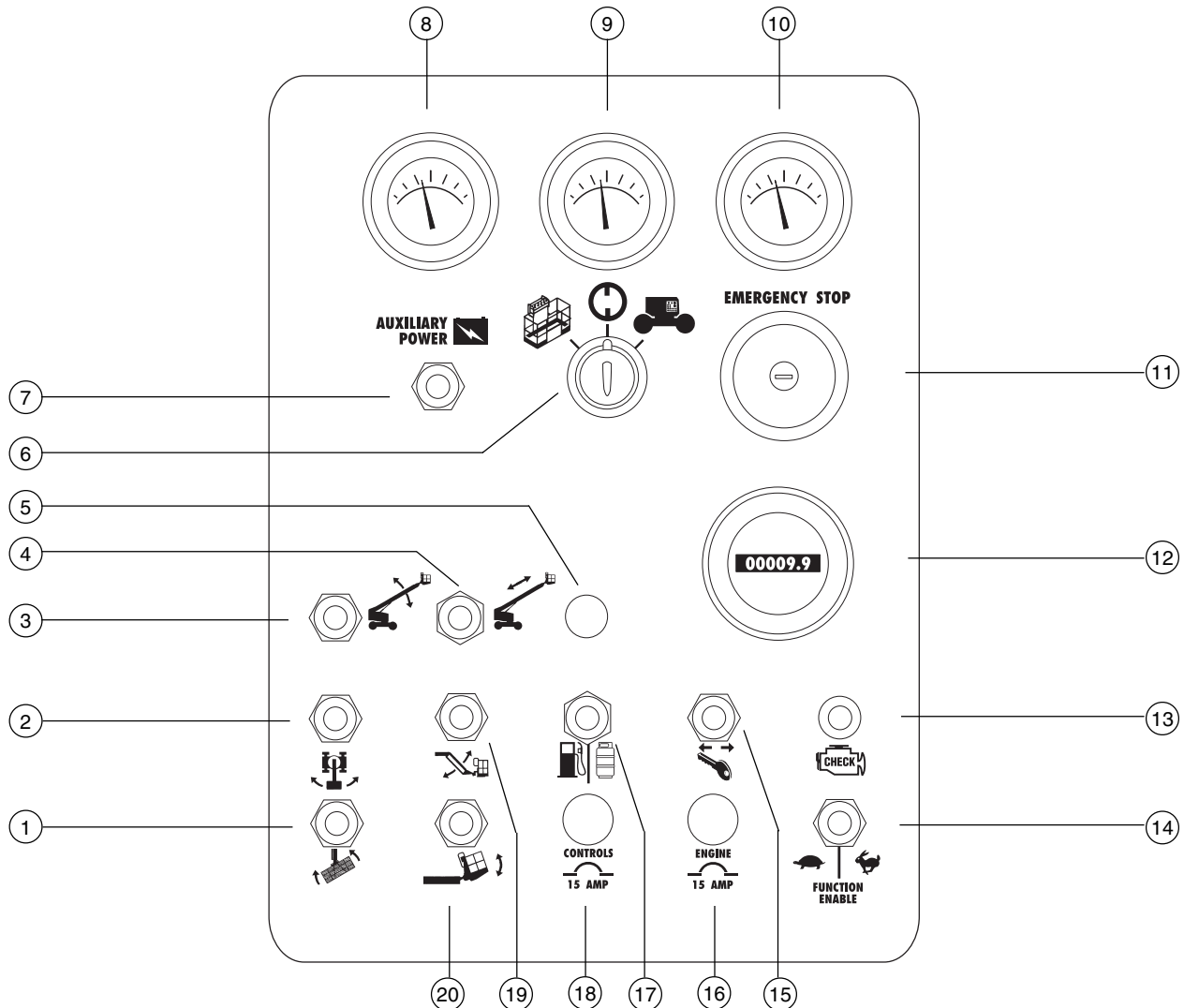

## Ground Control Panel

- |    |   |    |  |
|----|---|----|--|
| 1  | Platform rotate switch  | 11 | Emergency Stop button  |
| 2  | Turntable rotate switch   | 12 | Hour meter   |
| 3  | Boom up/down switch   | 13 | Gasoline/LPG models: Check engine light<br>Deutz Diesel models: Glow plug switch<br>(option) |
| 4  | Boom extend/retract switch  | 14 | Function enable switch   |
| 5  | not used  | 15 | Engine start switch  |
| 6  | Key switch for platform/off/ground selection  | 16 | 15A breaker for engine electrical circuits   |
| 7  | Auxiliary power switch  | 17 | Gasoline/LPG select switch   |
| 8  | Gasoline/LPG models: Water temperature<br>gauge<br>Deutz Diesel models: Oil temperature gauge | 18 | 15A breaker for control electrical circuits  |
| 9  | Oil pressure gauge  | 19 | S-65 only: Jib boom up/down switch   |
| 10 | Voltage gauge   | 20 | Platform level switch  |

CONTROLS

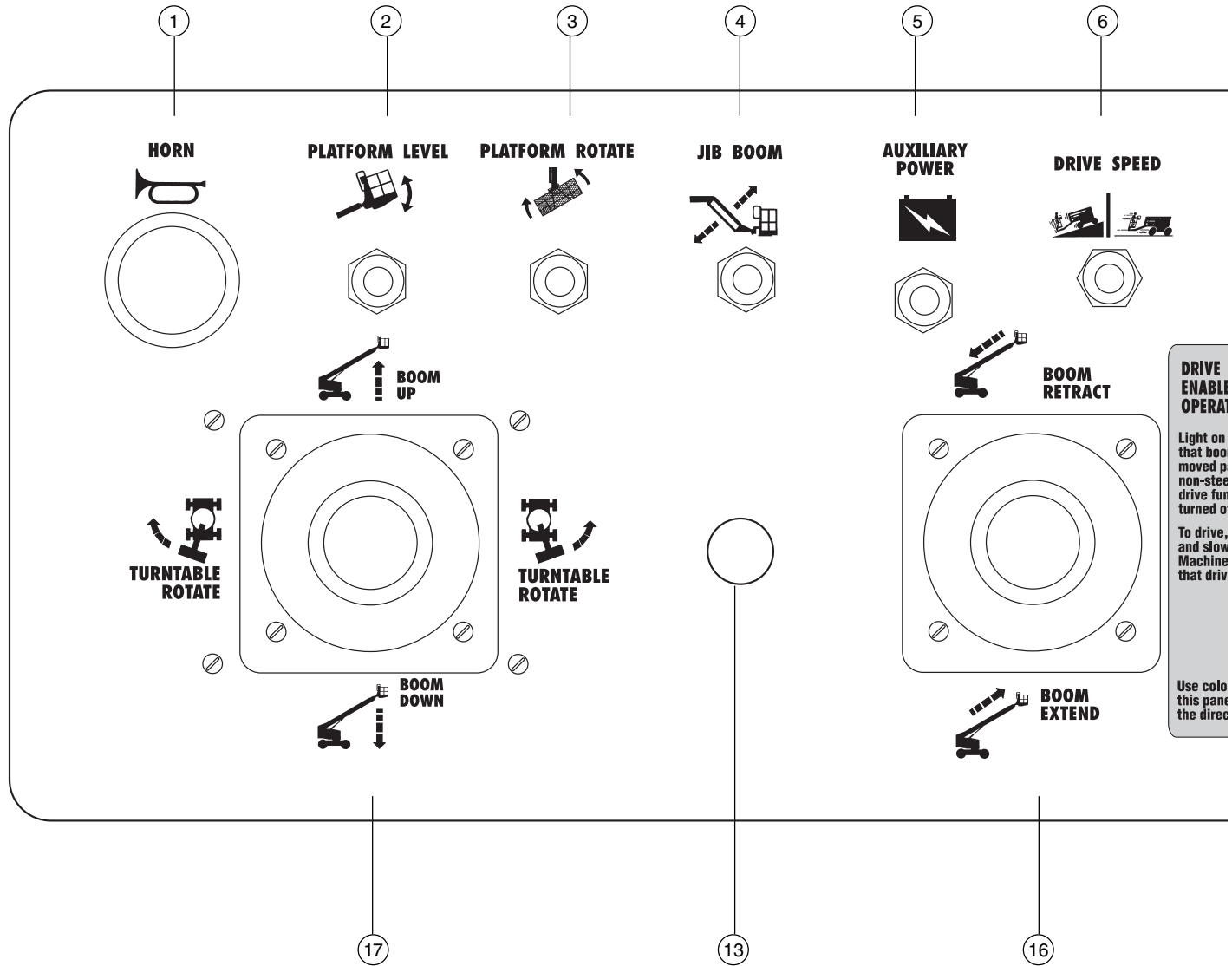

**Platform Control Panel**

- 1 Service horn button
- 2 Platform level switch
- 3**  
**Platform rotate switch**
- 4 S-65 only: Jib boom up/down switch
- 5 Auxiliary power switch
- 6 Drive speed select switch

- 7 Check engine light
- 8 Engine start switch
- 9 Engine idle (rpm) select switch
  - Rabbit & Foot Switch: foot switch activated high idle
  - Turtle: low idle
  - Rabbit: high idle
- 10 Gasoline/LPG models: Gasoline/LPG select switch  
Deutz Diesel models: Glow plug switch (option)

CONTROLS

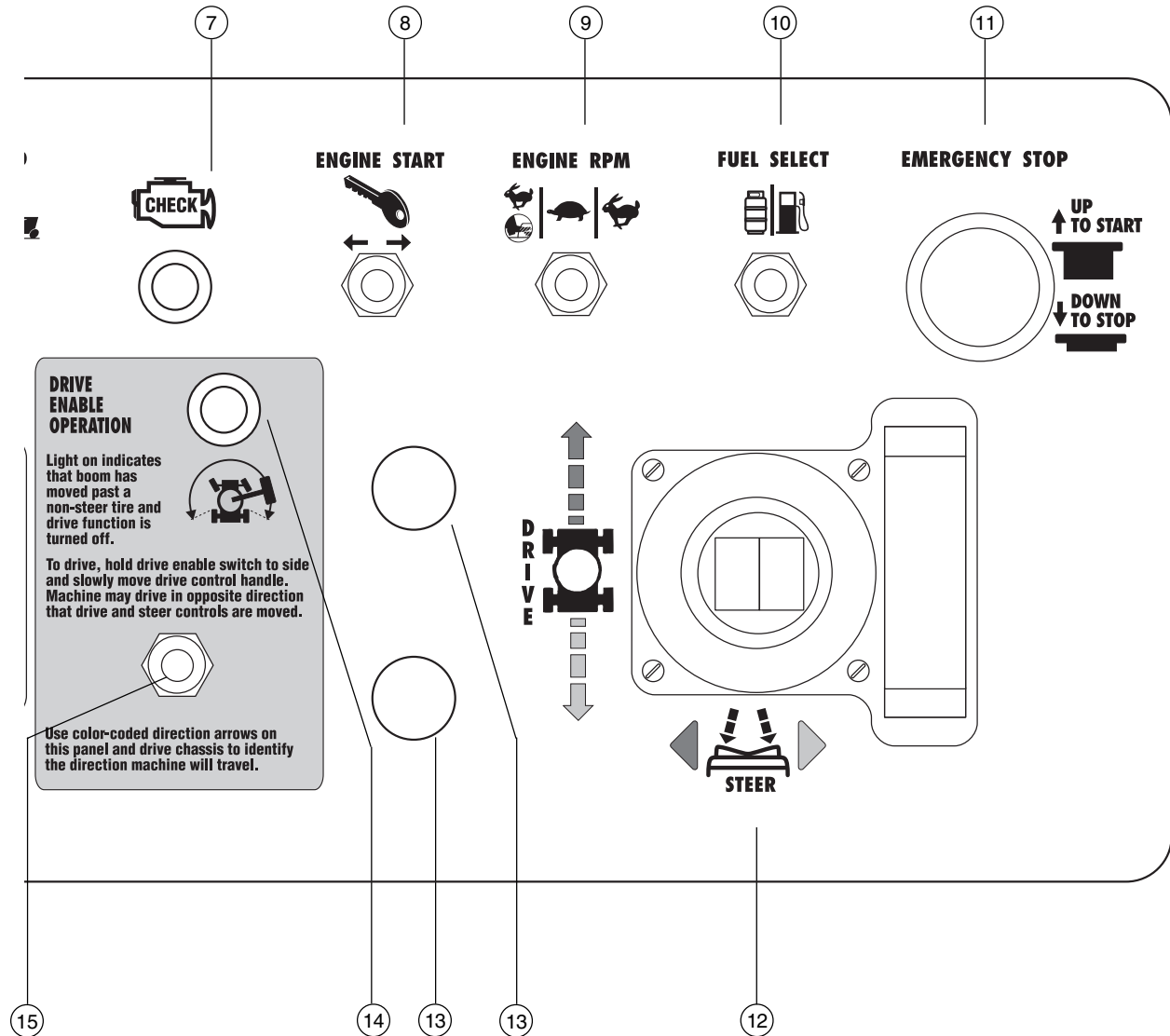

11 Emergency Stop button

15 Drive enable switch

12 Proportional control handle for drive function and thumb rocker for steer function

16 Proportional control handle for boom extend/retract

13 used for optional equipment

13 used for optional equipment

14 Drive enable indicator light

17 Dual axis proportional control handle for boom up/down and turntable rotate left/right functions

# Pre-operation Inspection



---

## Do Not Operate Unless:

- You learn and practice the principles of safe machine operation contained in this operator's manual.

1 Avoid hazardous situations.

**2 Always perform a pre-operation inspection.**

**Know and understand the above principles before going on to the next section.**

3 Always perform function tests prior to use.

4 Inspect the work place.

5 Only use the machine as it was intended.

## Fundamentals

It is the responsibility of the operator to perform a Pre-operation Inspection and routine maintenance.

The Pre-operation Inspection is a visual inspection performed by the operator prior to each work shift. The inspection is designed to discover if anything is apparently wrong with a machine before the operator performs the function tests.

The Pre-operation inspection also serves to determine if routine maintenance procedures are required. Only routine maintenance items specified in this manual may be performed by the operator.

Refer to the list on the next page and check each of the items and locations for modifications, damage or loose or missing parts.

A damaged or modified machine must never be used. If damage or any variation from factory delivered condition is discovered, the machine must be tagged and removed from service.

Repairs to the machine may only be made by a qualified service technician, according to the manufacturer's specifications. After repairs are completed, the operator must perform a pre-operation inspection again before going on to the function tests.

Scheduled maintenance inspections shall be performed by qualified service technicians, according to the manufacturer's specifications and the requirements listed in the responsibilities manual.

## PRE-OPERATION INSPECTION

## Pre-operation Inspection

---

- ❑ Be sure that the operator's, safety and responsibilities manuals are complete, legible and in the storage container located in the platform.
- ❑ Be sure that all decals are legible and in place. See Decals section.
- ❑ Check for engine oil leaks and proper oil level. Add oil if needed. See Maintenance section.
- ❑ Check for hydraulic oil leaks and proper oil level. Add oil if needed. See Maintenance section.
- ❑ Check for engine coolant leaks and proper level of coolant. Add coolant if needed. See Maintenance section.
- ❑ Check for battery fluid leaks and proper fluid level. Add distilled water if needed. See Maintenance section.
- ❑ Check for proper tire pressure. Add air if needed. See Maintenance section.

Check the following components or areas for damage and improperly installed, loose or missing parts:

- ❑ Electrical components, wiring and electrical cables
- ❑ Hydraulic hoses, fittings, cylinders and manifolds
- ❑ Fuel and hydraulic tanks
- ❑ Drive and turntable motors and drive hubs
- ❑ Boom wear pads
- ❑ Tires and wheels
- ❑ Engine and related components

- ❑ Limit switches and horn
- ❑ Alarms and beacons (if equipped)
- ❑ Nuts, bolts and other fasteners
- ❑ Platform entry mid-rail or gate

Check entire machine for:

- ❑ Crack in welds or structural components
- ❑ Dents or damage to machine
- ❑ Be sure that all structural and other critical components are present and all associated fasteners and pins are in place and properly tightened.
- ❑ After you complete your inspection, be sure that all compartment covers are in place and latched.

# Maintenance



## Observe and Obey:

- ☑ Only routine maintenance items specified in this manual shall be performed by the operator.
- ☑ Scheduled maintenance inspections shall be completed by qualified service technicians, according to the manufacturer's specifications and the requirements specified in the responsibilities manual.

## Maintenance Symbols Legend

### NOTICE

The following symbols have been used in this manual to help communicate the intent of the instructions. When one or more of the symbols appear at the beginning of a maintenance procedure, it conveys the meaning below.



Indicates that tools will be required to perform this procedure.



Indicates that new parts will be required to perform this procedure.



Indicates that a cold engine is required before performing this procedure.

## Check the Engine Oil Level



Maintaining the proper engine oil level is essential to good engine performance and service life. Operating the machine with an improper oil level can damage engine components.

### NOTICE

Check the oil level with the engine off.

- 1 Check the oil dipstick.

**Gasoline/LPG Engine:** located above the bellhousing on the bulkhead side of the engine.

**Diesel Engine:** located on the engine block near the engine oil filter.

- ⊙ Result: The oil level should be at the full mark on the dipstick. Add oil as needed.

---

### Ford LRG-425 EFI Engine

**Oil capacity (including filter)** 4.5 quarts 4.3 liters

---

### Oil viscosity requirements

below 60°F / 15.5°C	5W-30
-10° to 90°F / -23° to 32°C	5W-30
above -10°F / -23°C	5W-30
above 25°F / -4°C	10W-30

Use oils meeting API classification SH or SG grade. Units ship with 10-40 CC/SG.

---

MAINTENANCE

<b>Deutz F4L 1011F Engine</b>	11 quarts
<b>Oil capacity (including filter)</b>	10.5 liters

**Oil viscosity requirements**

below 60°F / 15.5°C (synthetic)	5W-30
-10°F to 90°F / -23°C to 32°C	10W-40
above -4°F / -34°C	15W-40

Engine oil should have properties of API classification CC/SE or CC/SF grades.  
Units ship with 10-40 CC/SG.

<b>Perkins 704-30 Engine</b>	9.6 quarts	9 liters
<b>Oil capacity (including filter)</b>		

**Oil viscosity requirements**

below 60°F / 15.5°C	15W-40
-10°F to 90°F / -23°C to 32°C	10W-30
above -4°F / -34°C	15W-40

Engine oil should have properties of API classification CF4 grade.  
Units ship with 10-40 CC/SG.

## Check the Hydraulic Oil Level



Maintaining the hydraulic oil at the proper level is essential to machine operation. Improper hydraulic oil levels can damage hydraulic components. Daily checks allow the inspector to identify changes in oil level that might indicate the presence of hydraulic system problems.

- 1 Be sure that the boom is in the stowed position, then visually inspect the sight gauge located on the side of the hydraulic oil tank. Add oil as needed.
- ⊙ Result: The hydraulic oil level should be within the top 2 inches (5 cm) of the sight gauge.

**Hydraulic oil specifications**

Hydraulic oil type	Dexron equivalent
Tank capacity	45 gallons 170 liters
Hydraulic system (including tank)	53 gallons 201 liters

## MAINTENANCE

## Check the Engine Coolant Level - Liquid Cooled Models



Maintaining the engine coolant at the proper level is essential to engine service life. Improper coolant level will affect the engine's cooling capability and damage engine components. Daily checks will allow the inspector to identify changes in coolant level that might indicate cooling system problems.

**CAUTION** Burn hazard. Beware of hot engine parts and coolant. Contact with hot engine parts and/or coolant may cause severe burns.

- 1 Check the fluid level in the coolant recovery tank. Add fluid as needed.
- ⊙ Result: The fluid level should be at the FULL mark.

**NOTICE** Do not remove the radiator cap.

## Check the Batteries



Proper battery condition is essential to good engine performance and operational safety. Improper fluid levels or damaged cables and connections can result in engine component damage and hazardous conditions.

**WARNING** Electrocutation hazard. Contact with hot or live circuits may result in death or serious injury. Remove all rings, watches and other jewelry.

**WARNING** Bodily injury hazard. Batteries contain acid. Avoid spilling or contacting battery acid. Neutralize battery acid spills with baking soda and water.

- 1 Put on protective clothing and eye wear.
- 2 Be sure that the battery cable connections are free of corrosion.
- 3 Be sure that the battery hold downs and cable connections are tight.
- 4 Remove the battery vent caps.
- 5 Check the battery acid level. If needed, replenish with distilled water to the bottom of the battery fill tube. Do not overfill.
- 6 Install the vent caps.

**NOTICE** Adding terminal protectors and a corrosion preventative sealant will help eliminate corrosion on the battery terminals and cables.



MAINTENANCE

## Check the Tire Pressure



**NOTICE** This procedure does not need to be performed on machines equipped with the foam-filled tire option.

**AWARNING** Bodily injury hazard. An over-inflated tire can explode and could cause death or serious injury.

**AWARNING** Tip-over hazard. Do not use temporary flat tire repair products.

To safeguard maximum stability, achieve optimum machine handling and minimize tire wear, it is essential to maintain proper pressure in all air-filled tires.

- 1 Check each tire with an air pressure gauge. Add air as needed.

### Tire specifications

Tire size	15-19.5NHS
Pressure	85 psi 5.86 bar

## Scheduled Maintenance

The scheduled maintenance items must be completed by a person trained and qualified to perform maintenance on this machine according to the procedures found in the service manual for this machine.

Inspections and maintenance described below require the qualified entity to record and retain records of all inspections and maintenance items for four years.

Machines that have been out of service for more than three months must receive the quarterly inspection before placing the machine back into service.

## The Schedule

There are five types of maintenance inspections that must be performed according to a schedule—daily, quarterly, six months, annual, two year. To account for repeated procedures, the *Scheduled Maintenance Procedures Section and the Maintenance Inspection Report* have been divided into five subsections—A, B, C, D and E. Use the following chart to determine which group(s) of procedures are required to perform a scheduled inspection.

Inspection	Table or Checklist
Daily or every 8 hours	A
Quarterly or every 250 hours	A + B
Six months or every 500 hours	A + B + C
Annual or every 1000 hours	A + B + C + D
Two year or every 2000 hours	A + B + C + D + E

## Maintenance Inspection Report

The maintenance inspection report contains checklists for each type of scheduled inspection.

Make copies of the *Maintenance Inspection Report* to use for each inspection. Store completed forms for three years.

# Function Tests



## Do Not Operate Unless:

- You learn and practice the principles of safe machine operation contained in this operator's manual.

- 1 Avoid hazardous situations.
- 2 Always perform a pre-operation inspection.

### 3 Always perform function tests prior to use.

### Know and understand the above principles before going on to the next section.

- 4 Inspect the work place.
- 5 Only use the machine as it was intended.

## Fundamentals

The Function Tests are designed to discover any malfunctions before the machine is put into service. The operator must follow the step-by-step instructions to test all machine functions.

A malfunctioning machine must never be used. If malfunctions are discovered, the machine must be tagged and removed from service. Repairs to the machine may only be made by a qualified service technician, according to the manufacturer's specifications.

After repairs are completed, the operator must perform a pre-operation inspection and function tests again before putting the machine into service.

- 1 Select a test area that is firm, level and free of obstruction.

## At the Ground Controls

- 2 Turn the key switch to ground control.
- 3 Pull out the red Emergency Stop button to the ON position.
- ⊙ Result: The beacon (if equipped) should flash.
- 4 Start the engine (see Operating Instructions section).

## Test Emergency Stop

- 5 Push in the red Emergency Stop button to the OFF position.
- ⊙ Result: The engine should turn off and all functions should not operate.
- 6 Pull out the red Emergency Stop button to the ON position and restart the engine.

## Test the Machine Functions

- 7 Do not hold the function enable switch to either side. Attempt to activate each boom and platform function toggle switch.
- ⊙ Result: All boom and platform functions should **not** operate.
- 8 Hold the function enable switch to either side and activate each boom and platform function toggle switch.
- ⊙ Result: All boom and platform functions should operate through a full cycle. The descent alarm (if equipped) should sound while the boom is lowering.

Machines equipped with Platform Level Control Disable Function: The platform level toggle switch will not operate when the boom is raised or extended past the drive speed limit switches.

## FUNCTION TESTS

**Test the Tilt Sensor**

- 9 Pull out the platform red Emergency Stop button to the ON position. Turn the key switch to platform control.
  - 10 Open the tank side turntable cover and locate the tilt sensor next to the control box.
  - 11 Press down one side of the tilt sensor.
- ☉ Result: The alarm, located in the platform, should sound.

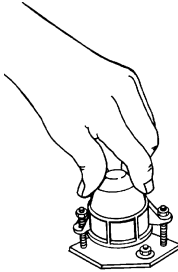
**Test Auxiliary Controls**

- 12 Turn the key switch to ground control and shut the engine off.
  - 13 Pull out the red Emergency Stop button to the ON position.
  - 14 Simultaneously hold the auxiliary power switch on and activate each boom function toggle switch.
- Note: To conserve battery power, test each function through a partial cycle.
- ☉ Result: All boom functions should operate.

**At the Platform Controls****Test Emergency Stop**

- 15 Turn the key switch to platform control and restart the engine.
  - 16 Push in the platform red Emergency Stop button to the OFF position.
- ☉ Result: The engine should turn off and all functions should not operate.
- 17 Pull out the red Emergency Stop button and restart the engine.

**Test the Hydraulic Oil Return Filter**

- 18 Move the engine idle select switch to high idle (rabbit symbol).
  - 19 Locate and check the hydraulic filter condition indicator.
- ☉ Result: The filter should be operating with the plunger in the green area.
- 20 Move the engine idle select switch to foot switch activated high idle (rabbit and foot switch symbol).

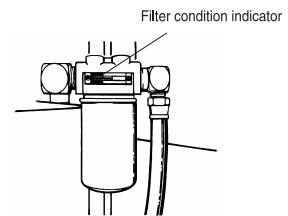
**Test the Service Horn**

- 19 Push the horn button.
- ☉ Result: The service horn should sound.

## FUNCTION TESTS

**Test the Foot Switch**

- 20 Push in the platform Emergency Stop button to the OFF position.
  - 21 Pull out the Emergency Stop button to the ON position but do not start the engine.
  - 22 Press down the foot switch and attempt to start the engine by moving the start toggle switch to either side.
- ⊙ Result: The engine should **not** start.
- 23 Do not press down the foot switch and restart the engine.
  - 24 Move the lift/drive select switch to the lift position (if equipped).
  - 25 Do not press down the foot switch. Test each machine function.
- ⊙ Result: The machine functions should **not** operate.

**Test Machine Functions**

- 26 Move the lift/drive select switch to the lift position (if equipped).
  - 27 Press down the foot switch.
  - 28 Activate each machine function control handle or toggle switch.
- ⊙ Result: All boom/platform functions should operate through a full cycle.

Machines equipped with Platform Level Control Disable Function: The platform level toggle switch will not operate when the boom is raised or extended past the drive speed limit switches.

**Test the Steering**

- 29 Move the lift/drive select switch to the drive position (if equipped).
  - 30 Press down the foot switch.
  - 31 Depress the thumb rocker switch on top of the drive control handle in the direction identified by the blue triangle on the control panel.
- ⊙ Result: The steer wheels should turn in the direction that the blue triangles point on the drive chassis.
- 32 Depress the thumb rocker switch in the direction identified by the yellow triangle on the control panel.
- ⊙ Result: The steer wheels should turn in the direction that the yellow triangles point on the drive chassis.

**Test Drive and Braking**

- 33 Move the lift/drive select switch to the drive position (if equipped).
  - 34 Press down the foot switch.
  - 35 Slowly move the drive control handle in the direction indicated by the blue arrow on the control panel until the machine begins to move, then return the handle to the center position.
- ⊙ Result: The machine should move in the direction that the blue arrow points on the drive chassis, then come to an abrupt stop.
- 36 Slowly move the drive control handle in the direction indicated by the yellow arrow on the control panel until the machine begins to move, then return the handle to the center position.
- ⊙ Result: The machine should move in the direction that the yellow arrow points on the drive chassis, then come to an abrupt stop.

Note: The brakes must be able to hold the machine on any slope it is able to climb.

## FUNCTION TESTS

**Test the Oscillating Axle  
(if equipped)**

- 37 Move the lift/drive select switch to the drive position (if equipped).
- 38 Start the engine from the platform controls.
- 39 Drive the right steer tire up onto a 6 inch (15.2 cm) block or curb.
- ⦿ Result: The three remaining tires should stay in firm contact with the ground.
- 40 Drive the left steer tire up onto a 6 inch (15.2 cm) block or curb.
- ⦿ Result: The three remaining tires should stay in firm contact with the ground.
- 41 Drive both steer tires up onto a 6 inch (15.2 cm) block or curb.
- ⦿ Result: The non-steer tires should stay in firm contact with the ground.

**Test the Drive Enable System**

- 42 Move the lift/drive select switch to the lift position (if equipped).
- 43 Press down the foot switch and lower the boom to the stowed position.
- 44 Rotate the turntable until the boom moves past one of the non-steering wheels.

- ⦿ Result: The drive enable indicator light should come on and remain on while the boom is anywhere in the range shown.



- 45 Move the lift/drive select switch to the drive position (if equipped).
- 46 Move the drive control handle off center.
- ⦿ Result: The drive function should **not** operate.
- 47 Move and hold the drive enable toggle switch to either side and slowly move the drive control handle off center.
- ⦿ Result: The drive function should operate.

Note: When the drive enable system is in use, the machine may drive in the opposite direction that the drive and steer control handle is moved.

Use the color-coded direction arrows on the platform controls and the drive chassis to identify the direction of travel.

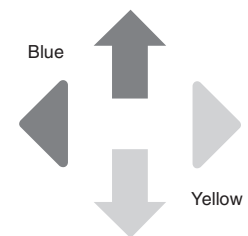
**Test Limited Drive Speed**

- 48 Move the lift/drive select switch to the lift position (if equipped).
- 49 Press down the foot switch.
- 50 Raise the boom to just above horizontal.

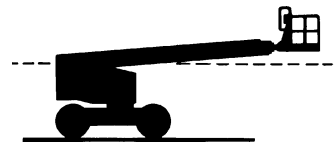

- 51 Move the lift/drive select switch to the drive position (if equipped).
- 52 Slowly move the drive control handle to the full drive position.
- ⦿ Result: The maximum achievable drive speed with the boom raised should not exceed 1 foot per second (0.3 meters per second).

## FUNCTION TESTS

53 Move the lift/drive select switch to the lift position (if equipped).

54 Lower the boom to the stowed position.

55 Extend the boom 1 foot (30 cm).

56 Move the lift/drive select switch to the drive position (if equipped).

57 Slowly move the drive control handle to the full drive position.

- ⦿ Result: The maximum achievable drive speed with the boom extended should not exceed 1 foot per second (0.3 meters per second).

If the drive speed with the boom raised or extended exceeds 1 foot per second (0.3 meters per second), immediately tag and remove the machine from service.

### Test Auxiliary Controls

58 Shut off the engine.

59 Pull out the red Emergency Stop button to the ON position.

60 Press down the foot switch.

61 Move the lift/drive select switch to the lift position (if equipped).

62 Simultaneously hold the auxiliary power switch on and activate each function control handle or toggle switch.

Note: To conserve battery power, test each function through a partial cycle.

- ⦿ Result: All boom and steer functions should operate. Drive functions should not operate with auxiliary power.

### Test the Lift/Drive Select Switch (if equipped)

63 Move the lift/drive select switch to the lift position.

64 Press down the foot switch.

65 Move the drive control handle off center.

- ⦿ Result: No drive functions should operate.

66 Activate each boom function toggle switch.

- ⦿ Result: All boom functions should operate.

67 Move the lift/drive select switch to the drive position.

68 Press down the foot switch.

69 Activate each boom function toggle switch.

- ⦿ Result: No boom functions should operate.

70 Move the drive control handle off center.

- ⦿ Result: The drive functions should operate.

71 Repair any malfunctions before operating the machine.

---

# Work Place Inspection



---

## Do Not Operate Unless:

- You learn and practice the principles of safe machine operation contained in this operator's manual.

- 1 Avoid hazardous situations.
- 2 Always perform a pre-operation inspection.
- 3 Always perform function tests prior to use.

### **4 Inspect the work place.**

**Know and understand the above principles before going on to the next section.**

- 5 Only use the machine as it was intended.

## Work Place Inspection

Be aware of and avoid the following hazardous situations:

- drop-offs or holes
- bumps, floor obstructions or debris
- overhead obstructions and high voltage conductors
- hazardous locations
- inadequate surface support to withstand all load forces imposed by the machine
- wind and weather conditions
- the presence of unauthorized personnel
- other possible unsafe conditions

## Fundamentals

The Work Place Inspection helps the operator determine if the work place is suitable for safe machine operation. It should be performed by the operator prior to moving the machine to the work place.

It is the operator's responsibility to read and remember the work place hazards, then watch for and avoid them while moving, setting up and operating the machine.

# Operating Instructions



## Do Not Operate Unless:

- You learn and practice the principles of safe machine operation contained in this operator's manual.

- 1 Avoid hazardous situations.
- 2 Always perform a pre-operation inspection.
- 3 Always perform function tests prior to use.
- 4 Inspect the work place.
- 5 Only use the machine as it was intended.**

## Fundamentals

The Operating Instructions section provides instructions for each aspect of machine operation. It is the operator's responsibility to follow all the safety rules and instructions in the operator's, safety and responsibilities manuals.

Using the machine for anything other than lifting personnel and tools to an aerial work site is unsafe and dangerous.

Only trained and authorized personnel should be permitted to operate a machine. If more than one operator is expected to use a machine at different times in the same work shift, they must all be qualified operators and are all expected to follow all safety rules and instructions in the operator's, safety and responsibilities manuals. That means every new operator should perform a pre-operation inspection, function tests, and a work place inspection before using the machine.

## Starting the Engine

- 1 At the ground controls, turn the key switch to the desired position.
- 2 Be sure both ground and platform control red Emergency Stop buttons are pulled out to the ON position.
- 3 Gasoline/LPG models: Choose fuel by moving the fuel select switch to the desired position.
- 4 Move the engine start toggle switch to either side. If the engine fails to start or dies, the restart delay will disable the start switch for 3 seconds.



If the engine fails to start after 15 seconds of cranking, determine the cause and repair any malfunction. Wait 60 seconds before trying to start again.

All models: In extreme cold conditions, 20°F (-6°C) and below, warm the engine for 5 minutes to prevent hydraulic system damage.

Gasoline/LPG models: In extreme cold conditions, 20°F (-6°C) and below, the machine should be started on gasoline, then switched to LPG.

## Emergency Stop

Push in either the ground or platform red Emergency Stop button to the OFF position to stop all functions and turn the engine off.

Repair any function that operates when the Emergency Stop button is pushed in.

Selecting and operating the ground controls will override the platform Emergency Stop button.



## OPERATING INSTRUCTIONS

## Auxiliary Controls

Use auxiliary power if the primary power source (engine) fails.

- 1 Turn the key switch to ground or platform control.
- 2 Pull out the red Emergency Stop button to the ON position.
- 3 Move the lift/drive select switch to the lift position (if equipped) when operating the auxiliary controls from the platform.
- 4 Press down the foot switch when operating the auxiliary controls from the platform.
- 5 Simultaneously hold the auxiliary power switch ON and activate desired function.

The drive function will not operate with auxiliary power.

## Operation from Ground

- 1 Turn the key switch to ground control.
- 2 Pull out the red Emergency Stop button to the ON position.
- 3 Gasoline/LPG models: Choose fuel by moving fuel select switch to desired position.
- 4 Start the engine.

### To Position Platform

- 1 Hold the function enable switch to either side.
- 2 Move the appropriate toggle switch according to the markings on the control panel.

Drive and steer functions are not available from the ground controls.

Machines equipped with Platform Level Control Disable Function: The platform level toggle switch will not operate when the boom is raised or extended past the drive speed limit switches.

## Operation from Platform

- 1 Turn the key switch to platform control.
- 2 Pull out both ground and platform red Emergency Stop buttons to the ON position.
- 3 Gasoline/LPG models: Choose fuel by moving the fuel select switch to the desired position.
- 4 Start the engine. Do not press down the foot switch when starting the engine.

### To Position Platform

- 1 Move the lift/drive select switch to the lift position (if equipped).
- 2 Press down the foot switch.
- 3 Slowly move the appropriate function control handle or toggle switch according to the markings on the control panel.

Machines equipped with Platform Level Control Disable Function: The platform level toggle switch will not operate when the boom is raised or extended past the drive speed limit switches.

### To Steer

- 1 Move the lift/drive select switch to the drive position (if equipped).
- 2 Press down the foot switch.
- 3 Turn the steering wheels with the thumb rocker switch located on top of the drive control handle.

Use the color-coded direction arrows on the platform controls and the drive chassis to identify the direction the wheels will turn.

## OPERATING INSTRUCTIONS

### To Drive

- 1 Move the lift/drive select switch to the drive position (if equipped).
- 2 Press down the foot switch.
- 3 Increase speed: Slowly move the drive control handle off center.

Decrease speed: Slowly move the drive control handle toward center.

Stop: Return the drive control handle to center or release the foot switch.

Use the color-coded direction arrows on the platform controls and the drive chassis to identify the direction the machine will travel.

Machine travel speed is restricted when the boom is raised or extended.

### Drive Enable

Light ON indicates that the boom has moved just past either non-steering wheel and drive function has been interrupted.

To drive, hold the drive enable switch to either side and slowly move the drive control handle off center.

Be aware that the machine may move in the opposite direction that the drive and steer controls are moved.

Always use the color-coded direction arrows on the platform controls and the drive chassis to identify the direction the machine will travel.

### Generator

To operate the generator, move the generator toggle switch to the generator position. The engine will continue to run but no drive or platform functions will operate.

Plug power tool into the power to platform GFCI outlet.

To resume machine functions, move the generator toggle switch to machine functions position. All functions will operate.

### Engine Idle Select (rpm)

Select engine idle (rpm) using the symbols on the control panel.

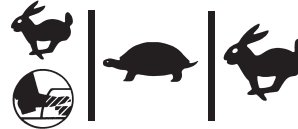

- Rabbit and foot switch symbol: foot switch activated high idle
- Turtle symbol: low idle
- Rabbit symbol: high idle

### Check Engine Light (if equipped)

Light on and engine stopped: Tag the machine and remove from service.

Light on and engine still running: Contact service personnel within 24 hours.

### Stopping the Engine

Push in the red Emergency Stop button and turn the key switch to the OFF position.

### After Each Use

- 1 Select a safe parking location—firm level surface, clear of obstruction and traffic.
- 2 Retract and lower the boom to the stowed position.
- 3 Rotate the turntable so that the boom is between the non-steering wheels.
- 4 Turn the key switch to the OFF position and remove the key to secure from unauthorized use.
- 5 Chock the wheels.

# Transport Instructions



## Observe and Obey:

- ☑ Transport vehicle must be parked on a level surface.
- ☑ Transport vehicle must be secured to prevent rolling while machine is being loaded.
- ☑ Be sure vehicle capacity, loading surfaces and straps or lines are sufficient to withstand machine weight. See Specifications section.

## Securing to Truck or Trailer for Transit

Always use the turntable rotation lock pin each time the machine is transported.

Always chock machine wheels in preparation for transport.

Use tie points on drive chassis for anchoring down to transport surface.

Use the lower platform mount between the boom end and the platform to secure the boom from side-to-side movement. Do not use excessive downward force when securing the boom section.

Use chains or straps of ample load capacity.

Turn the key switch to the OFF position and remove the key before transporting.

Inspect the entire machine for loose or unsecured items.

## Free-wheel Configuration for Winching

Chock the wheels to prevent the machine from rolling.

2WD models: Release non-steer wheel brakes by turning over the torque hub disconnect caps (see below).

4WD models: Release wheel brakes by turning over all four torque hub disconnect caps (see below).

Be sure the winch line is properly secured to the drive chassis tie points and the path is clear of all obstructions.

Reverse procedures described to re-engage brakes.

Note: The pump free-wheel valve should always remain closed.

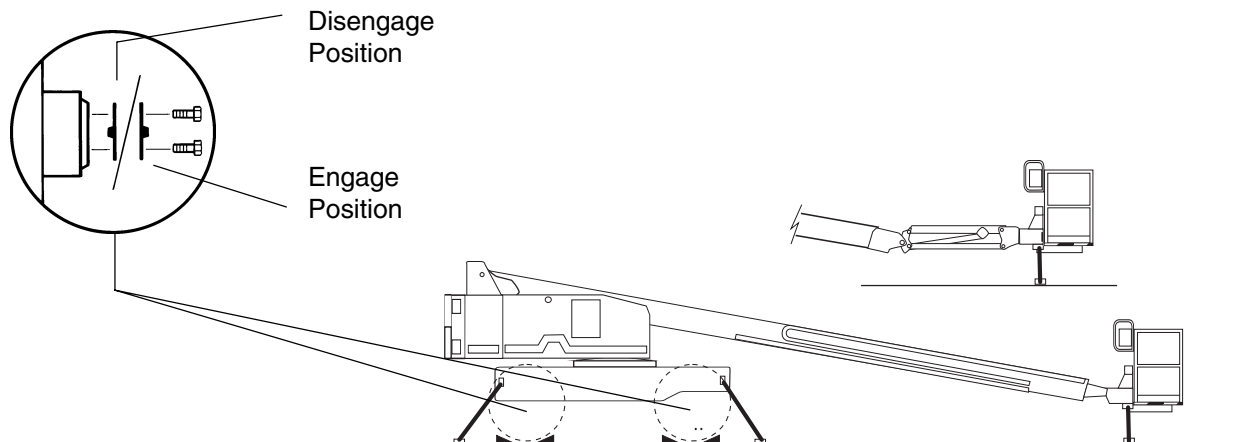

# Decals

## Decal Inspection

Use the picture on the next page to verify that all decals are legible and in place.

Below is a numerical list with quantities and descriptions.

Part No.	Decal Description	Quantity
25994	Caution - Component Damage Hazard	1
27204	Arrow - Blue	1
27205	Arrow - Yellow	1
27206	Triangle- Blue	2
27207	Triangle - Yellow	2
27564	Danger - Electrocution Hazard	3
28157	Label - Dexron	1
28158	Label - Unleaded	2
28159	Label - Diesel	2
28160	Label - Liquid Petroleum Gas	1
28161	Danger - Crushing Hazard	7
28163	Notice - Maximum Side Force - 150 lbs	1
28164	Notice - Hazardous Materials	1
28165	Notice - Foot Switch	1
28171	Label - No Smoking	2
28174	Label - Power to Platform, 230V	2
28175	Caution - Compartment Access	1
28176	Notice - Missing Manuals	1
28177	Warning - Platform Rotate	2
28181	Warning - No Step or Ride	1
28235	Label - Power to Platform, 115V	2
28236	Warning - Failure To Read . . .	1
30080*	Notice - Maximum Load 500 lbs	1
31060	Danger - Tip-over Hazard, Interlock	1
32700	Danger - Safety Rules	2
32726	Label - Glow Plug (option)	1
32728	Label - Generator (option)	1

Part No.	Decal Description	Quantity
33885	Serial Plate - S-65	1
33952	Danger - Tilt-Alarm	1
33973	Notice - Tire Pressure	2
35599	Notice - Align Air Hoses	1
40434	Label - Lanyard Anchorage	4
43594*	Notice - Maximum Load 750 lbs	1
43595	Danger - Tip-over, Tires (foam-filled)	1
43647	Notice - Operating Instructions	2
43649	Ground Control Panel	1
43663	Notice - Function Enable	1
44769	Lift/Drive Select	1
44981	Airline to Platform	2
44986	Notice - Maximum Manual Force - 90 lbs	1
49741	Notice - Ford Engine Specs-LRG-425 EFI	1
49926	Ground Control Panel	1
52156	Platform Control Panel	1
52966	Cosmetic - 4 x 2	1
52967	Cosmetic - 4 x 4	1
53037	Notice - Deutz Diesel Engine Specs	1
62076	Cosmetic - Genie S-60	1
62077	Cosmetic - S-60	1
62078	Cosmetic - Genie S-65	1
62079	Cosmetic - S-65	1
64361	Notice - Perkins Diesel Engine Specs	1
72160	Ground Control Panel	1
72162	Platform Control Panel	1

\*Please reference the Specifications section or the chart on page 2 to determine the capacity of your machine.

DECALS

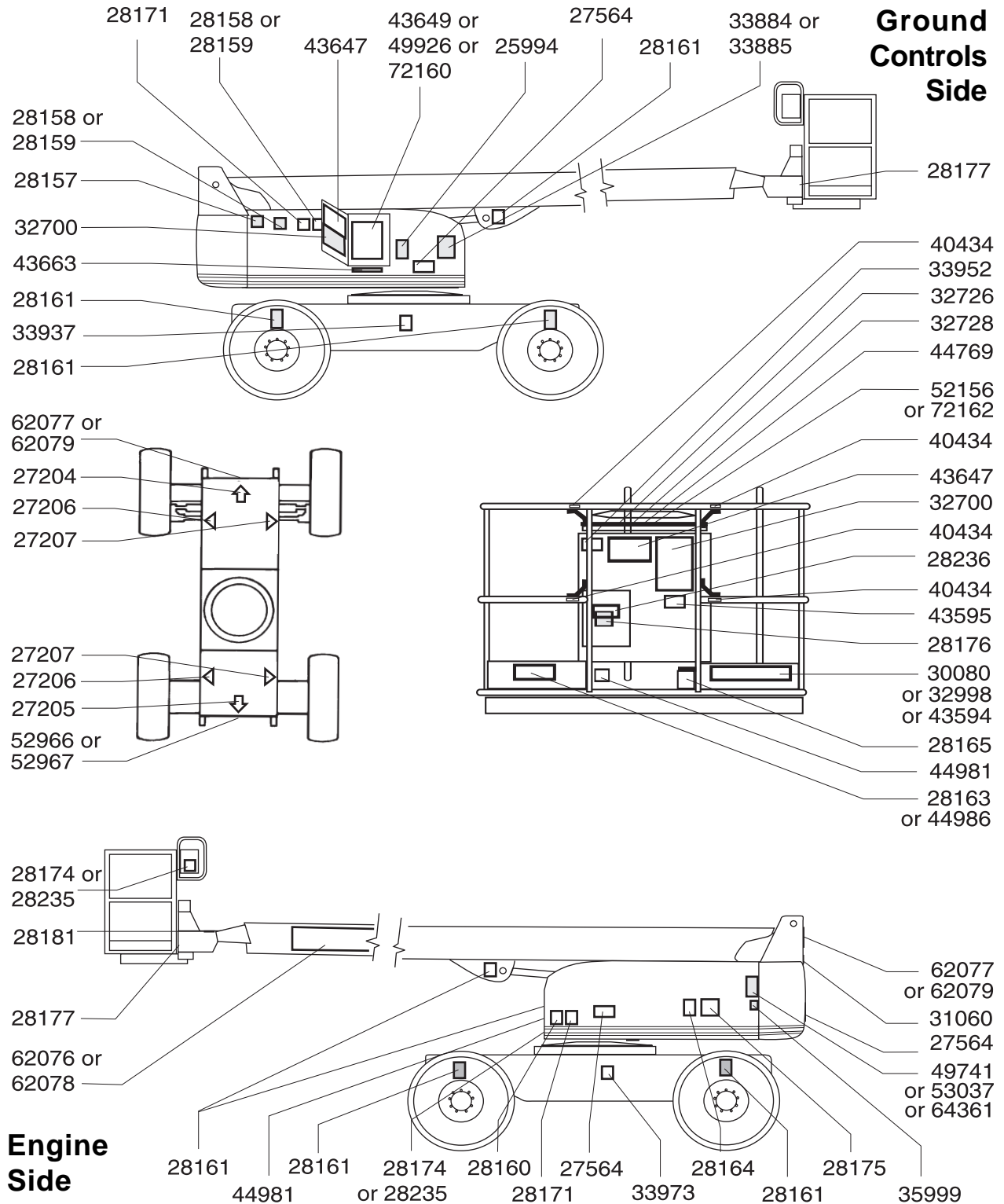

# Specifications

Model	S-60	S-65
Height, working maximum	66 ft 20.1 m	71 ft 21.6 m
Height, platform maximum	60 ft 18.3 m	65 ft 19.8 m
Height, stowed maximum 2.74 m    2.74 m	9 ft	9 ft
Horizontal reach maximum	51 ft 3 in 15.6 m	56 ft 4 in 17.2 m
Width	8 ft 2.43 m	8 ft 2.43 m
Length, stowed	27 ft 2 in 8.3 m	30 ft 10 in 9.4 m
Maximum load capacity 6 foot platform	600 lb 272 kg	500 lb 227 kg
Maximum load capacity 8 foot platform	500 lb 227 kg	500 lb 227 kg
Maximum load capacity 6 foot platform with foam-filled tires and proper counterweight configuration	750 lb 340 kg	N/A N/A
Wheelbase	9 ft 0 in 2.7 m	9 ft 0 in 2.7 m
Turning radius (outside)	22 ft 2 in 6.75 m	22 ft 2 in 6.75 m
Turning radius (inside)	12 ft 1 in 3.7 m	12 ft 1 in 3.7 m
Turntable rotation (degrees)		continuous
Turntable tailswing	3 ft 3 <sup>1</sup> / <sub>2</sub> in 100 cm	3 ft 3 <sup>1</sup> / <sub>2</sub> in 100 cm
Power source (choice)	Ford 63 Hp Gasoline/LPG LRG-423 or LRG-425 EFI Deutz 56 Hp Diesel F4L 1011	
<b>Drive speeds</b>	<b>2WD</b>	<b>4WD</b>
Drive speed, stowed	4.4 mph	3.0 mph
Gasoline/LPG models	7.1 km/h	4.8 km/h
	40 ft/6.2 sec	40 ft/9.1 sec
	12.2 m/6.2 sec	12.2 m/9.1 sec
Drive speed, stowed	4.0 mph	2.8 mph
Deutz Diesel models	6.4 km/h	4.5 km/h
	40 ft/6.8 sec	40 ft/9.7 sec
	12.2 m/6.8 sec	12.2 m/9.7 sec
Drive speed, raised or extended	0.6 mph	0.6 mph
- all models	1.0 km/h	1.0 km/h
	40 ft/40 sec	40 ft/40 sec
	12.2 m/40 sec	12.2 m/40 sec

Model	S-60	S-65
Controls	12V DC proportional	
Platform dimensions, 6 foot (length x width)	72 in x 30 in 1.8 m x 76 cm	72 in x 30 in 1.8 m x 76 cm
Platform dimensions, 8 foot (length x width)	96 in x 36 in 2.4 m x 91 cm	96 in x 36 in 2.4 m x 91 cm
Platform leveling	self-leveling	self-leveling
Platform rotation	160°	160°
AC outlet in platform	standard	standard
Hydraulic pressure (maximum) (boom functions)	2600 psi 179 bar	2900 psi 200 bar
Tire size	15-19.5 NHS	15-19.5 NHS
Gradeability, stowed (2WD/4WD)		28% / 40 %
Ground clearance	12 in 30 cm	12 in 30 cm
Hydraulic tank capacity	45 gallons 170 liters	45 gallons 170 liters
Fuel tank capacity	30 gallons 114 liters	30 gallons 114 liters
Weight	26,060 lbs 11,821 kg	28,400 lbs 12,882 kg
Airborne noise emissions		80 dB
Maximum sound level at normal operating workstations (A-weighted)		

**Continuous improvement of our products is a Genie policy. Product specifications are subject to change without notice or obligation.**

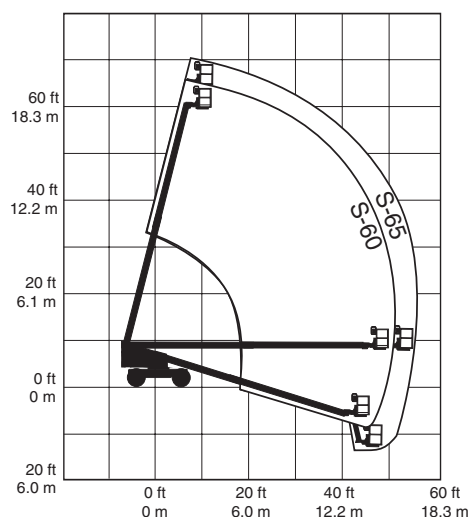

# California Proposition 65

# WARNING

The exhaust from this product contains chemicals known to the State of California to cause cancer, birth defects or other reproductive harm.

**Genie Holland**

**Phone** +31 70 51 78836  
**Fax** +31 70 51 13993

**Genie Scandinavia**

**Phone** +46 31 3409612  
**Fax** +46 31 3409613

**Genie France**

**Phone** +33 (0)2 37 26 09 99  
**Fax** +33 (0)2 37 26 09 98

**Genie Ibérica**

**Phone** +34 93 579 5042  
**Fax** +34 93 579 5059

**Genie Germany**

**Phone** +49 (0)4202 88520  
**Fax** +49 (0)4202 8852-20

**Genie U.K.**

**Phone** +44 (0)1476 584333  
**Fax** +44 (0)1476 584334

**Genie Mexico City**

**Phone** +52 5 653 03 84  
**Fax** +52 5 664 40 16

**Genie North America**

**Phone** 425.881.1800  
**Toll Free** USA and Canada  
800.536.1800  
**Fax** 425.883.3475

**Genie Australia Pty Ltd.**

**Phone** +61 7 3375 1660  
**Fax** +61 7 3375 1002

**Genie China**

**Phone** +86 21 53852570  
**Fax** +86 21 53852569

**Genie Malaysia**

**Phone** +60 4 228 1235  
**Fax** +60 4 226 6872

**Genie Japan**

**Phone** +81 3 3453 6082  
**Fax** +81 3 3453 6083

**Genie Korea**

**Phone** +82 2 558 7267  
**Fax** +82 2 558 3910

**Genie Africa**

**Phone** +27 11 455 0373  
**Fax** +27 11 455 0355

**Genie Latin America**

**Phone** +55 11 4055 2499  
**Fax** +55 11 4043 1661

Distributed By: