

Genie®



Operator's Manual

with Maintenance Information

Second Edition
Second Printing
Part No. 82262

GS™-2668 DC
GS™-3268 DC

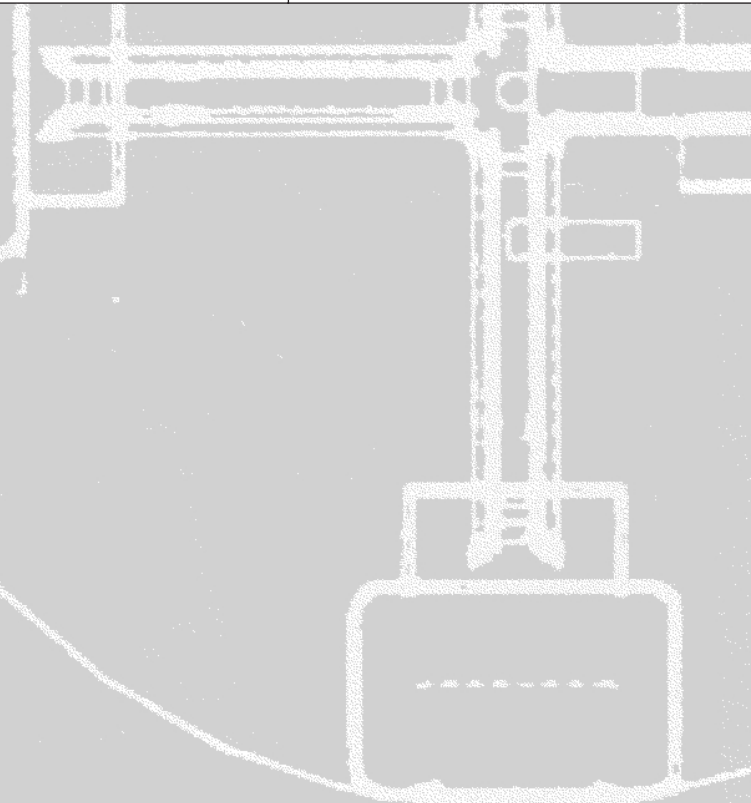

Important

Read, understand and obey these safety rules and operating instructions before operating this machine. Only trained and authorized personnel shall be permitted to operate this machine. This manual should be considered a permanent part of your machine and should remain with the machine at all times. If you have any questions, please call Genie Industries.

Contents

	Page
Safety	1
Legend	8
Controls	9
Pre-operation Inspection	11
Maintenance	13
Function Tests	15
Work Place Inspection	20
Operating Instructions	21
Transport Instructions	25
Decals	26
Specifications	28

Contact us:

Internet: <http://www.genielift.com>
 e-mail: techpub@genieind.com

Copyright © 1999 by Genie Industries

First Edition: Sixth Printing, January 2002

Second Edition: Second Printing, March 2002

"Genie" is a registered trademark of Genie Industries in the U.S.A. and many other countries. "GS" is a trademark of Genie Industries.

These machines comply with
 ANSI/SIA 92.6-1999.

 Printed on recycled paper

Printed in U.S.A.

Safety Rules



Danger

Failure to obey the instructions and safety rules in this manual will result in death or serious injury.

Do Not Operate Unless:

- You learn and practice the principles of safe machine operation contained in this operator's manual.

1 Avoid hazardous situations.

Know and understand the safety rules before going on to the next section.

2 Always perform a pre-operation inspection.

3 Always perform function tests prior to use.

4 Inspect the workplace.

5 Only use the machine as it was intended.

- You read, understand and obey:

Manufacturer's instructions and safety rules—safety and operator's manuals and machine decals

employer's safety rules and worksite regulations

applicable governmental regulations

- You** are properly trained to safely operate the machine.

SAFETY RULES

Electrocution Hazards

This machine is **not** electrically insulated and will **not** provide protection from contact with or proximity to electrical current.

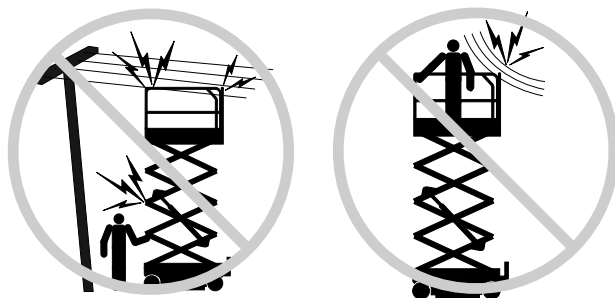

Maintain safe distances from electrical power lines and apparatus in accordance with applicable governmental regulations and the following chart.

Voltage Phase to Phase	Minimum Safe Approach Distance	
	Feet	Meters
0 to 300V	Avoid Contact	
300V to 50KV	10	3.05
50KV to 200KV	15	4.60
200KV to 350KV	20	6.10
350KV to 500KV	25	7.62
500KV to 750KV	35	10.67
750KV to 1000KV	45	13.72

Allow for platform movement, electrical line sway or sag and beware of strong or gusty winds.

Keep away from the machine if it contacts energized power lines. Personnel on the ground or in the platform must not touch or operate the machine until energized power lines are shut off.

Do not operate the machine during lightning or storms.

Do not use the machine as a ground for welding.

Tip-over Hazards

Occupants and equipment shall not exceed the maximum platform capacity or the maximum capacity of the platform extension.

Maximum capacity - GS-2668DC		
Platform retracted	1250 lbs	567 kg
Platform extended - Platform only	950 lbs	431 kg
Platform extended - Extension only	300 lbs	136 kg
Maximum occupants - ANSI and CSA	4	
Maximum occupants - CE	4	
Outdoor use	4	
Indoor use only	4	



1250 lbs / 567 kg Extension only Platform only
300 lbs / 136 kg 950 lbs / 431kg

Maximum capacity - GS-3268DC		
Platform retracted	1000 lbs	454 kg
Platform extended - Platform only	700 lbs	318 kg
Platform extended - Extension only	300 lbs	136 kg
Maximum occupants - ANSI and CSA	4	
Maximum occupants - CE	4	
Outdoor use	2	
Indoor use only	4	



1000 lbs / 454 kg Extension only Platform only
300 lbs / 136 kg 700 lbs / 318 kg

SAFETY RULES

Do not alter or disable the limit switches.

Do not drive over 0.5 mph / 0.8 km/h with the platform raised.

Do not depend on the tilt alarm as a level indicator. The tilt alarm sounds on the chassis and in the platform when the machine is on a severe slope.

If the tilt alarm sounds:
Lower the platform. Move the machine to a firm, level surface. If the tilt alarm sounds when the platform is raised, use extreme caution to lower the platform.

Do not raise the platform unless the machine is on a firm, level surface.

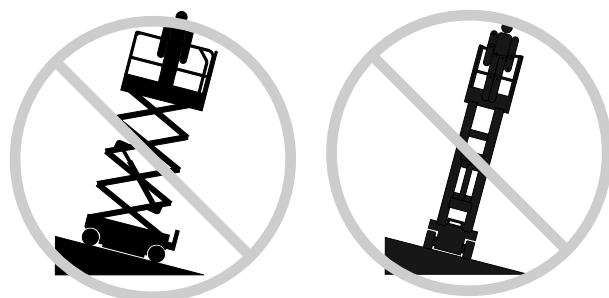

Do not use the platform controls to free a platform that is caught, snagged or otherwise prevented from normal motion by an adjacent structure. All personnel must be removed from the platform before attempting to free the platform using the ground controls.

Do not alter or disable machine components that in any way affect safety and stability.

Do not replace items critical to machine stability with items of different weight or specification.

Do not operate the machine in strong or gusty winds. Do not increase the surface area of the platform or the load. Increasing the area exposed to the wind will decrease machine stability.

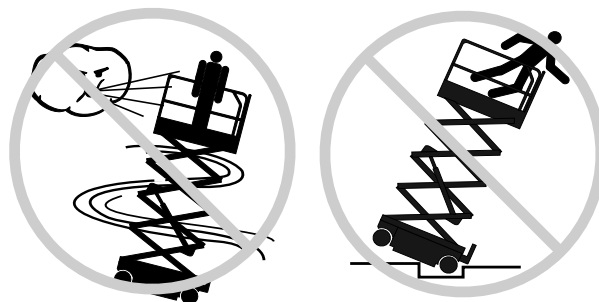

Do not drive the machine on or near uneven terrain, unstable surfaces or other hazardous conditions with the platform raised.

Use extreme care and slow speeds while driving the machine in stowed position across uneven terrain, debris, unstable or slippery surfaces and near holes and drop-offs.

Do not push off or pull toward any object outside of the platform.

GS-2668 DC

ANSI & CSA - 4 person	200 lbs / 890 N
CE - Indoor use only - 4 person	90 lbs / 400 N
CE - Outdoor use - 4 person	90 lbs / 400 N
Australia - Indoor use only - 4 person	90 lbs / 400 N
Australia - Outdoor use - 4 person	90 lbs / 400 N

GS-3268 DC

ANSI & CSA - 4 person	200 lbs / 890 N
CE - Indoor use only - 4 person	90 lbs / 400 N
CE - Outdoor use - 2 person	90 lbs / 400 N
Australia - Indoor use only - 4 person	90 lbs / 400 N
Australia - Outdoor use - 2 person	90 lbs / 400 N



SAFETY RULES

Do not modify or alter an aerial work platform. Mounting attachments for holding tools or other materials onto the platform, toeboards or guard rail system can increase the weight in the platform and the surface area of the platform or the load.

Do not place or attach fixed or overhanging loads to any part of this machine.



Do not place ladders or scaffolds in the platform or against any part of this machine.

Do not use the machine on a moving or mobile surface or vehicle.

Be sure all tires are in good condition, castle nuts are properly tightened and lock plates are properly installed.

Do not use the machine as a crane.

Do not push the machine or other objects with the platform.

Do not contact adjacent structures with the platform.

Do not tie the platform to adjacent structures.

Do not place loads outside the platform perimeter.

Do not use batteries that weigh less than the original equipment. Batteries are used as counterweight and are critical to machine stability. Each battery must weigh 65 pounds / 29.5 kg.

Fall Hazards



Occupants should wear a safety belt or harness and comply with applicable governmental regulations. Attach lanyard to anchor provided in platform.

Do not sit, stand or climb on the platform guard rails. Maintain a firm footing on the platform floor at all times.



Do not climb down from the platform when raised.

Keep the platform floor clear of debris.

Close the entry gate before operating.

Do not operate the machine unless the guard rails are properly installed and the entry is secured for operation.

Bodily Injury Hazard

Do not operate the machine with a hydraulic oil or air leak. An air leak or hydraulic leak can penetrate and/or burn skin.

SAFETY RULES

Collision Hazards

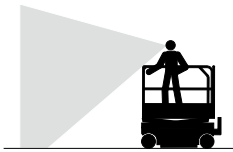

Be aware of limited sight distance and blind spots when driving or operating.

Be aware of extended platform position when moving the machine.

The machine must be on a level surface or secured before releasing the brakes.

It is recommended that operators wear an approved hard hat when operating the machine.

Check the work area for overhead obstructions or other possible hazards.



Be aware of crushing hazards when grasping the platform guard rail.

Observe and use the color-coded direction arrows on the platform controls and platform decal plate for drive and steer functions.

Do not operate a machine in the path of any crane or moving overhead machinery unless the controls of the crane have been locked out and/or precautions have been taken to prevent any potential collision.

No stunt driving or horseplay while operating a machine.

Do not lower the platform unless the area below is clear of personnel and obstructions.



Limit travel speed according to the condition of the ground surface, congestion, slope, location of personnel and any other factors which may cause collision.

Component Damage Hazards

Do not use machine as a ground for welding.

Explosion and Fire Hazards

Do not operate the machine in hazardous locations or locations where potentially flammable or explosive gases or particles may be present.

SAFETY RULES

Damaged Machine Hazards

Do not use a damaged or malfunctioning machine.

Conduct a thorough pre-operation inspection of the machine and test all functions before each work shift. Immediately tag and remove from service a damaged or malfunctioning machine.

Be sure all maintenance has been performed as specified in this manual and the appropriate service manual.

Be sure all decals are in place and legible.

Be sure the operator's, safety and responsibilities manuals are complete, legible and in the storage container located on the platform.

Crushing Hazards

Keep hands and limbs out of scissors.

Use common sense and planning when operating the machine with the controller from the ground. Maintain safe distances between the operator, the machine and fixed objects.

Maintain a firm grasp on the platform rail when pulling the snap pin. Do not allow the platform guard rails to fall.

Decal Legend

Genie product decals use symbols, color coding and signal words to identify the following:



Safety alert symbol—used to alert personnel to potential personal injury hazards. Obey all safety messages that follow this symbol to avoid possible injury or death.



Red—used to indicate the presence of an imminently hazardous situation which, if not avoided, will result in death or serious injury.



Orange—used to indicate the presence of a potentially hazardous situation which, if not avoided, could result in death or serious injury.



Yellow with safety alert symbol—used to indicate the presence of a potentially hazardous situation which, if not avoided, may cause minor or moderate injury.



Yellow without safety alert symbol—used to indicate the presence of a potentially hazardous situation which, if not avoided, may result in property damage.



Green—used to indicate operation or maintenance information.

SAFETY RULES

Battery Safety

Burn Hazards

Batteries contain acid. Always wear protective clothing and eyewear when working with batteries.

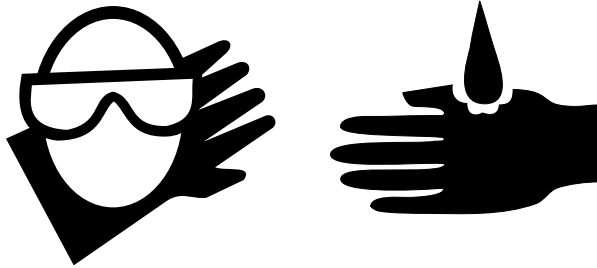

Avoid spilling or contacting battery acid. Neutralize battery acid spills with baking soda and water.

Do not expose the batteries or the charger to water or rain.

Explosion Hazards



Keep sparks, flames and lighted tobacco away from batteries. Batteries emit an explosive gas.

The battery tray should remain open during the entire charging cycle.

Do not contact the battery terminals or the cable clamps with tools that may cause sparks.

Component Damage Hazard

Do not use any battery charger greater than 48V to charge the batteries.

Electrocution Hazards



Connect the battery charger to a grounded, AC 3-wire electrical outlet only.

Inspect daily for damaged cord, cables and wires. Replace damaged items before operating.

Avoid electrical shock from contact with battery terminals. Remove all rings, watches and other jewelry.

Tip-over Hazard

Do not use batteries that weigh less than the original equipment. Batteries are used as counterweight and are critical to machine stability. Each battery must weigh 65 pounds / 29.5 kg.

Lifting Hazard

Use the appropriate number of people and proper lifting techniques when lifting batteries.

Legend

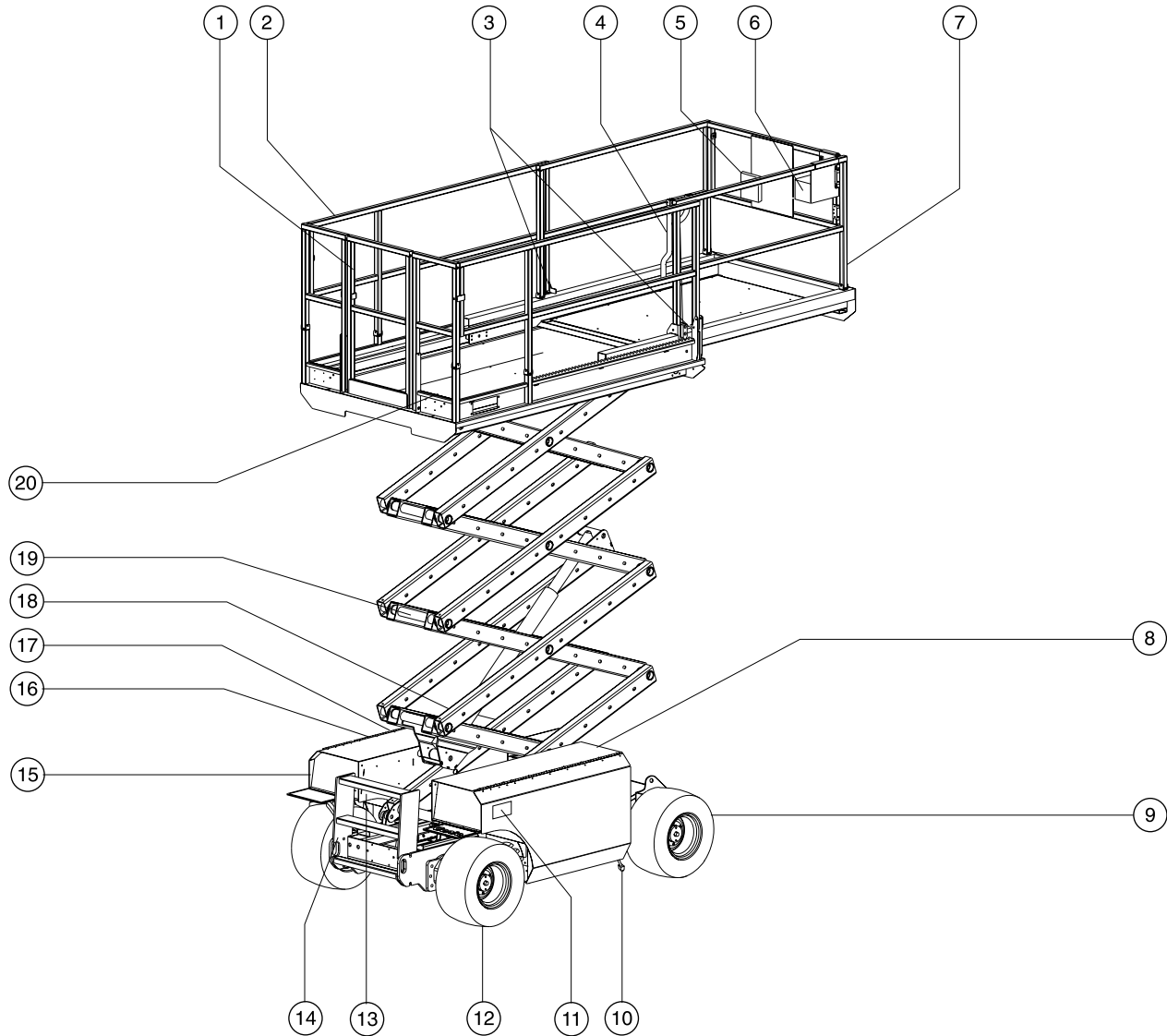

- | | | |
|---|--|--|
| 1 Platform entry gate | 10 Power to platform pigtail | 17 Hydraulic oil level indicator (under cover) |
| 2 Platform guard rails | 11 Power to charger pigtail and battery charger (under cover) | 18 Brake release pump knob and brake release knob (hidden from view in this picture) |
| 3 Lanyard anchorage point | 12 Non-steer tire | 19 Safety arm |
| 4 Platform extension lock handle (manual platform extension only) | 13 Tilt alarm (under cover) | 20 GFCI outlet |
| 5 Manual storage container | 14 Entry ladder/transport tie-down | |
| 6 Platform controls | 15 Ground controls with manual lowering and LED diagnostic readout | |
| 7 Platform extension | 16 Ground controls side cover | |
| 8 Battery side cover | | |
| 9 Steer tire | | |

Controls

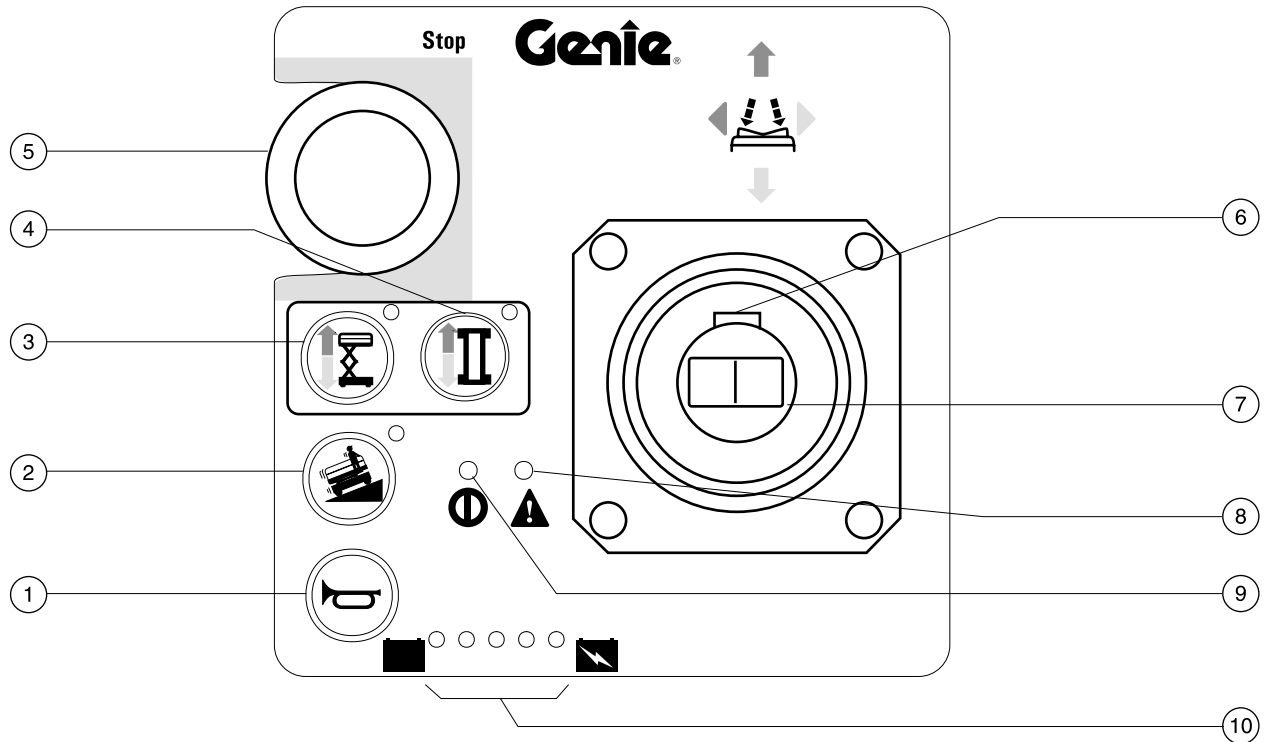

Platform Controls

- | | | | |
|---|---|----|--|
| 1 | Horn button | 7 | Proportional control handle for lift and drive functions and thumb rocker for steer function |
| 2 | Machine on incline button: Low speed operation for inclines | 8 | Error indicator light |
| 3 | Lift function select button with indicator light | 9 | Power light |
| 4 | Drive function select button with indicator light | 10 | Battery level indicator |
| 5 | Red Emergency Stop button | | |
| 6 | Function enable switch | | |

CONTROLS

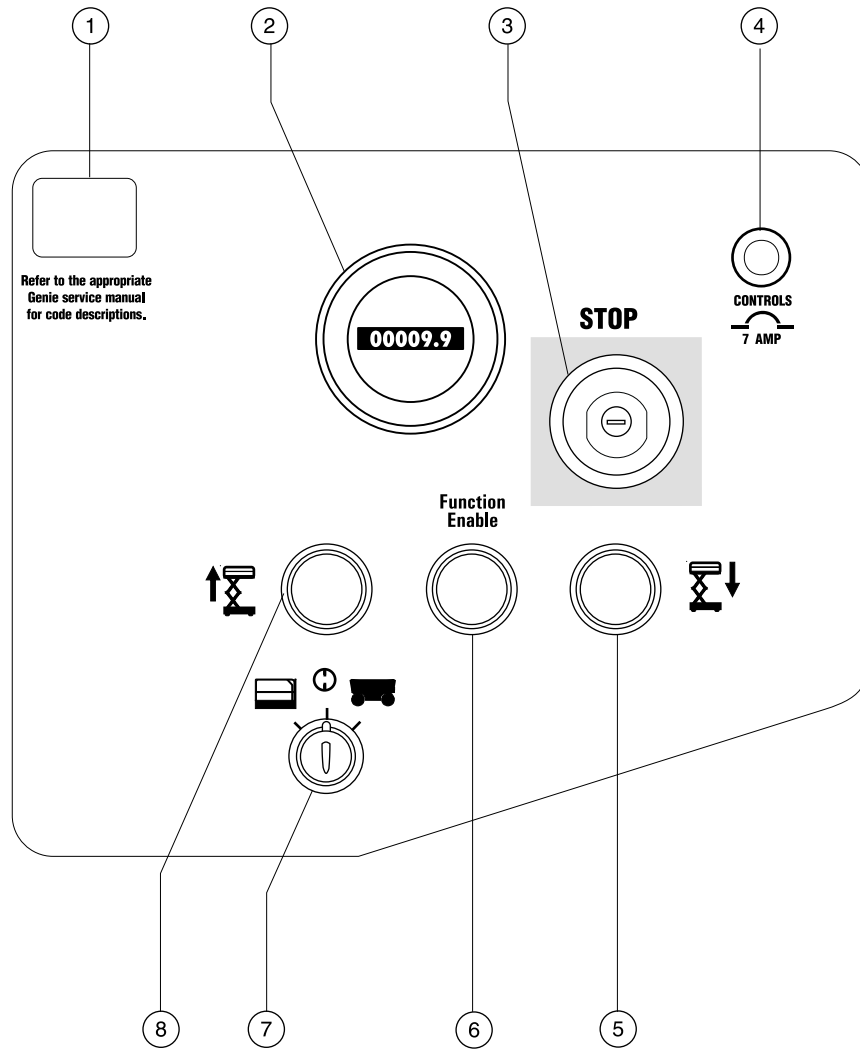

Ground Control Panel

- | | | | |
|---|--|---|---|
| 1 | LED diagnostic readout | 6 | Function enable button |
| 2 | Hour meter | 7 | Keyswitch for platform/off/ground control selection |
| 3 | Red Emergency Stop button | 8 | Platform up button |
| 4 | 7 amp circuit breaker for controls circuit | | |
| 5 | Platform down button | | |

Pre-operation Inspection



Do Not Operate Unless:

- You learn and practice the principles of safe machine operation contained in this operator's manual.

1 Avoid hazardous situations.

2 Always perform a pre-operation inspection.

Know and understand the pre-operation inspection before going on to the next section.

3 Always perform function tests prior to use.

4 Inspect the workplace.

5 Only use the machine as it was intended.

Fundamentals

It is the responsibility of the operator to perform a Pre-operation Inspection and routine maintenance.

The Pre-operation Inspection is a visual inspection performed by the operator prior to each work shift. The inspection is designed to discover if anything is apparently wrong with a machine before the operator performs the function tests.

The Pre-operation Inspection also serves to determine if routine maintenance procedures are required. Only routine maintenance items specified in this manual may be performed by the operator.

Refer to the list on the next page and check each of the items and locations for modifications, damage or loose or missing parts.

A damaged or modified machine must never be used. If damage or any variation from factory delivered condition is discovered, the machine must be tagged and removed from service.

Repairs to the machine may only be made by a qualified service technician, according to the manufacturer's specifications. After repairs are completed, the operator must perform a pre-operation inspection again before going on to the function tests.

Scheduled maintenance inspections shall be performed by qualified service technicians, according to the manufacturer's specifications and the requirements listed in the responsibilities manual.

PRE-OPERATION INSPECTION

Pre-operation Inspection

- Be sure that the operator's, safety and responsibilities manuals are complete, legible and in the storage container located on the platform.
- Be sure that all decals are legible and in place. See Decals section.
- Check for hydraulic oil leaks and proper oil level. Add oil if needed. See Maintenance section.
- Check for battery fluid leaks and proper fluid level. Add distilled water if needed. See Maintenance section.

Check the following components or areas for damage, modifications and improperly installed or missing parts:

- Electrical components, wiring and electrical cables
- Hydraulic power unit, tank, hoses, fittings, cylinders and manifolds
- Battery pack and connections
- Drive motors
- Wear pads
- Tires and wheels
- Limit switches, alarms and horn
- Nuts, bolts and other fasteners
- Platform entry gate
- Beacon and alarms (if equipped)
- Brake release components
- Safety arm

- Platform extension
- Scissor pins and retaining fasteners
- Platform control joystick
- Inverter (if equipped)

Check entire machine for:

- Cracks in welds or structural components
- Dents or damage to machine
- Be sure that all structural and other critical components are present and all associated fasteners and pins are in place and properly tightened.
- Be sure side rails are installed and snap pins and bolts are fastened
- Be sure that the chassis trays are in place, latched and properly connected.

Maintenance



Observe and Obey:

- ☑ Only routine maintenance items specified in this manual shall be performed by the operator.
- ☑ Scheduled maintenance inspections shall be completed by qualified service technicians, according to the manufacturer's specifications and the requirements specified in the responsibilities manual.

Maintenance Symbols Legend

NOTICE The following symbols have been used in this manual to help communicate the intent of the instructions. When one or more of the symbols appear at the beginning of a maintenance procedure, it conveys the meaning below.



Indicates that tools will be required to perform this procedure.



Indicates that new parts will be required to perform this procedure.

Check the Hydraulic Oil Level



Maintaining the hydraulic oil at the proper level is essential to machine operation. Improper hydraulic oil levels can damage hydraulic components. Daily checks allow the inspector to identify changes in oil level that might indicate the presence of hydraulic system problems.

NOTICE Perform this procedure with the platform in the stowed position.

- 1 Visually inspect the sight gauge located on the side of the hydraulic tank.
- ⦿ Result: The hydraulic oil level should be within the top 2 inches / 5 cm of the sight gauge.
- 2 Add oil if necessary. Do not overfill.

Hydraulic oil specifications

Hydraulic oil type	Dexron equivalent

MAINTENANCE

Check the Batteries



Proper battery condition is essential to good engine performance and operational safety. Improper fluid levels or damaged cables and connections can result in engine component damage and hazardous conditions.

NOTICE This procedure does not need to be performed on machines with sealed or maintenance-free batteries.

⚠ WARNING Electrocuting hazard. Contact with hot or live circuits may result in death or serious injury. Remove all rings, watches and other jewelry.

⚠ WARNING Bodily injury hazard. Batteries contain acid. Avoid spilling or contacting battery acid. Neutralize battery acid spills with baking soda and water.

NOTICE Perform this test after fully charging the batteries.

- 1 Put on protective clothing and eye wear.
- 2 Be sure that the battery cable connections are tight and free of corrosion.
- 3 Be sure that the battery hold down brackets are in place and secure.
- 4 Remove the battery vent caps.
- 5 Check the battery acid level of each battery. If needed, replenish with distilled water to the bottom of the battery fill tube. Do not overfill.
- 6 Install the vent caps.

NOTICE Adding terminal protectors and a corrosion preventative sealant will help eliminate corrosion on the battery terminals and cables.

Scheduled Maintenance

Maintenance performed quarterly, annually and every two years must be completed by a person trained and qualified to perform maintenance on the machine according to the procedures found in the service manual for this machine.

Machines that have been out of service for more than three months must receive the quarterly inspection before they are put back into service.

Function Tests



Do Not Operate Unless:

- You learn and practice the principles of safe machine operation contained in this operator's manual.

1 Avoid hazardous situations.

2 Always perform a pre-operation inspection.

3 Always perform function tests prior to use.

Know and understand the function tests before going on to the next section.

4 Inspect the workplace.

5 Only use the machine as it was intended.

Fundamentals

The Function Tests are designed to discover any malfunctions before the machine is put into service. The operator must follow the step-by-step instructions to test all machine functions.

A malfunctioning machine must never be used. If malfunctions are discovered, the machine must be tagged and removed from service. Repairs to the machine may only be made by a qualified service technician, according to the manufacturer's specifications.

After repairs are completed, the operator must perform a pre-operation inspection and function tests again before putting the machine into service.

FUNCTION TESTS

- 1 Select a test area that is firm, level and free of obstruction.
- 2 Be sure the battery pack is connected.

At the Ground Controls

- 3 Pull out the platform and ground red Emergency Stop button to the on position.
- 4 Turn the key switch to ground control.
- 5 Observe the diagnostic LED readout.

- ⦿ Result: LED should look like picture at right.

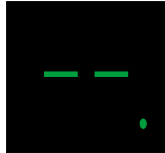
**Test the Emergency Stop**

- 6 Push in the ground red Emergency Stop button to the off position.
- ⦿ Result: No functions should operate.
- 7 Pull out the red Emergency Stop button to the on position.

Test the Up/Down Functions

The descent alarm and the motion alarm sound at 60 beeps per minute and sound at the chassis. The alarm that goes off when the machine is not level sounds at 180 beeps per minute and sounds at the chassis and in the platform.

- 8 Do not hold the function enable button and activate the platform up function.
- ⦿ Result: No function should operate.
- 9 Push and hold the function enable button and activate the platform up function.
- ⦿ Result: The platform should raise.

- 10 Push and hold the function enable button and activate the platform down function.

- ⦿ Result: The platform should lower. The descent alarm should sound while the platform is lowering.

Test the Manual Lowering

- 11 Push and hold the function enable button and activate the platform up function. Raise the platform approximately 2 feet / 60 cm.

- 12 Push in the red Emergency Stop button to the off position.

- 13 Pull out the red Emergency Stop button to the on position.

- 14 Push and hold the function enable button. Activate the down function.

- ⦿ Result: The platform should lower. The descent alarm will not sound.

- 15 Turn the key switch to platform control.

FUNCTION TESTS

At the Platform Controls**Test Emergency Stop**

16 Push in the platform red Emergency Stop button to the off position.

- ⦿ Result: No functions should operate.

17 Pull the red Emergency Stop button out to the on position.

- ⦿ Result: The green power light should come on.

Test the Horn

18 Push the horn button.

- ⦿ Result: The horn should sound.

Test the Function Enable Switch

19 Do not hold the function enable switch on the control handle.

20 Slowly move the control handle in the direction indicated by the blue arrow, then in the direction indicated by the yellow arrow.

- ⦿ Result: No functions should operate.

Test the Up/Down Functions

21 Press the lift function select button.

22 Press and hold the function enable switch on the control handle.

23 Slowly move the control handle in the direction indicated by the blue arrow.

- ⦿ Result: The platform should raise.

24 Release the control handle.

- ⦿ Result: The platform should stop raising.

25 Press and hold the function enable switch. Slowly move the control handle in the direction indicated by the yellow arrow.

- ⦿ Result: The platform should lower. The descent alarm should sound while the platform is lowering.

CE models: When lowering the platform, the platform should stop when it is 7 feet / 2.1 m from the ground. Be sure the area below the platform is clear of personnel and obstructions before continuing. To continue lowering, release the control handle, wait 5 seconds, then move the control handle again.

FUNCTION TESTS

Test the Steering

Note: When performing the steer and drive function tests, stand in the platform facing the steer end of the machine.

- 26 Press the drive function select button.
- 27 Press and hold the function enable switch.
- 28 Depress the thumb rocker switch on top of the control handle in the direction identified by the blue triangle on the control panel.
 - ⦿ Result: The steer wheels should turn in the direction that the blue triangle points on the control panel.
- 29 Depress the thumb rocker switch in the direction identified by the yellow triangle on the control panel.
 - ⦿ Result: The steer wheels should turn in the direction that the yellow triangle points on the control panel.

Test Drive and Braking

- 30 Press and hold the function enable switch.
- 31 Slowly move the control handle in the direction indicated by the blue arrow on the control panel until the machine begins to move, then return the handle to the center position.
 - ⦿ Result: The machine should move in the direction that the blue arrow points on the control panel, then come to an abrupt stop.
- 32 Press and hold the function enable switch.
- 33 Slowly move the control handle in the direction indicated by the yellow arrow on the control panel until the machine begins to move, then return the handle to the center position.
 - ⦿ Result: The machine should move in the direction that the yellow arrow points on the control panel, then come to an abrupt stop.

Note: The brakes must be able to hold the machine on any slope it is able to climb.

FUNCTION TESTS

Test Limited Drive Speed

- 34 Press the lift function select button.
- 35 Press and hold the function enable switch on the control handle.
- 36 Slowly move the control handle in the direction indicated by the blue arrow. Raise the platform approximately 6 feet / 1.83 m from the ground.
- 37 Press the drive function select button.
- 38 Press and hold the function enable switch.
- 39 Slowly move the control handle to the full drive position.
- ⦿ Result: The maximum achievable drive speed with the platform raised should not exceed 0.73 feet / 22 cm per second.

If the drive speed with the platform raised exceeds 0.73 feet / 22 cm per second, immediately tag and remove the machine from service.

Test the Tilt Sensor Operation

Note: Perform this test from the ground with the platform controller. Do not stand in the platform.

- 40 Fully lower the platform.
- 41 Drive both wheels on one side onto a 4 inch / 10 cm block or onto a curb.
- 42 Raise the platform approximately 8 feet / 2.4 m from the ground.
- ⦿ Result: The platform should stop and the tilt alarm will sound at 180 beeps per minute.
- 43 Push the drive select button.
- 44 Move the drive control handle in the direction indicated by the blue arrow, then move the drive control handle in the direction indicated by the yellow arrow.
- ⦿ Result: The drive function should not work in either direction.
- 45 Lower the platform and drive the machine off the block.

Workplace Inspection



Do Not Operate Unless:

- You learn and practice the principles of safe machine operation contained in this operator's manual.

- 1 Avoid hazardous situations.
- 2 Always perform a pre-operation inspection.
- 3 Always perform function tests prior to use.

4 Inspect the workplace.

Know and understand the workplace inspection before going on to the next section.

- 5 Only use the machine as it was intended.

Workplace Inspection

Be aware of and avoid the following hazardous situations:

- drop-offs or holes
- bumps, floor obstructions or debris
- overhead obstructions and high voltage conductors
- hazardous locations
- inadequate surface support to withstand all load forces imposed by the machine
- wind and weather conditions
- the presence of unauthorized personnel
- other possible unsafe conditions

Fundamentals

The Workplace Inspection helps the operator determine if the workplace is suitable for safe machine operation. It should be performed by the operator prior to moving the machine to the workplace.

It is the operator's responsibility to read and remember the workplace hazards, then watch for and avoid them while moving, setting up and operating the machine.

Operating Instructions



Do Not Operate Unless:

- You learn and practice the principles of safe machine operation contained in this operator's manual.
 - 1 Avoid hazardous situations.
 - 2 Always perform a pre-operation inspection.
 - 3 Always perform function tests prior to use.
 - 4 Inspect the workplace.
- 5 Only use the machine as it was intended.**

Fundamentals

The Operating Instructions section provides instructions for each aspect of machine operation. It is the operator's responsibility to follow all the safety rules and instructions in the operator's, safety and responsibilities manuals.

Using the machine for anything other than lifting personnel and tools to an aerial work site is unsafe and dangerous.

Only trained and authorized personnel should be permitted to operate a machine. If more than one operator is expected to use a machine at different times in the same work shift, they must all be qualified operators and are all expected to follow all safety rules and instructions in the operator's, safety and responsibilities manuals. That means every new operator should perform a pre-operation inspection, function tests, and a workplace inspection before using the machine.

Emergency Stop

Push in the red Emergency Stop button to the off position at the ground controls or the platform controls to stop all functions.

Repair any function that operates when either Emergency Stop button is pushed in.

OPERATING INSTRUCTIONS

Manual Lowering

- 1 Turn the key switch to ground control.
- 2 Pull out the ground and platform red Emergency Stop buttons to the on position.
- 3 Push and hold the function enable button.
- 4 Activate the platform down function.

Operation From Ground

- 1 Turn the key switch to ground control.
- 2 Pull out both ground and platform red Emergency Stop buttons to the on position.
- 3 Be sure the battery pack is connected before operating the machine.

To Position Platform

- 1 Push and hold the function enable button.
- 2 Activate the platform up or the platform down function.

Drive and steer functions are not available from the ground controls.

Operation From Platform

- 1 Turn the key switch to platform control.
- 2 Pull out the ground and platform red Emergency Stop button to the on position.
- 3 Be sure the battery pack is connected before operating the machine.

To Position Platform

- 1 Press the lift function select button.
- 2 Press and hold the function enable switch on the control handle.
- 3 Move the control handle according to the markings on the control panel.

To Steer

- 1 Press and hold the function enable switch.
- 2 Turn the steer wheels with the thumb rocker switch located on the top of the control handle.

OPERATING INSTRUCTIONS

To Drive

- 1 Press and hold the function enable switch.
- 2 Increase speed: Slowly move the control handle off center.

Decrease speed: Slowly move the control handle toward center.

Stop: Return the control handle to center or release the function enable switch.

Use the color-coded direction arrows on the platform controls and on the platform to identify the direction the machine will travel.

Machine travel speed is restricted when the platform is raised.

Battery condition will affect machine performance. When the battery charge indicator light flashes, the machine drive speed is limited and the lift function is disabled.

Drive Select Switch

Machine on incline symbol:
Low range operation for inclines

**To Extend and Retract Platform
(Manual Platform Extension)**

- 1 Lift the platform extension lock handle to the horizontal position.
- 2 Push the platform extension lock handle to extend the platform to the desired position.

Do not stand on the platform extension while trying to extend it.

- 3 Lower the platform extension lock handle.

**Operation From Ground with
Controller**

Maintain safe distances between the operator, the machine and fixed objects.

Be aware of the direction the machine will travel when using the controller.

After Each Use

- 1 Select a safe parking location—firm level surface, clear of obstructions and traffic.
- 2 Lower the platform.
- 3 Turn the key switch to the off position and remove the key to secure from unauthorized use.
- 4 Chock the wheels.
- 5 Charge the batteries.

OPERATING INSTRUCTIONS



Battery and Charger Instructions

Observe and Obey:

- Do not use an external charger or booster battery.
- Charge the battery in a well-ventilated area.
- Use proper AC input voltage for charging as indicated on the charger.
- Use only Genie authorized battery and charger.

To Charge Battery

- 1 Be sure the batteries are connected before charging the batteries.
- 2 Open the battery compartment. The compartment should remain open for the entire charging cycle.
- 3 Remove the battery vent caps and check the battery acid level. If necessary, add only enough distilled water to cover the plates. Do not overfill prior to the charge cycle.
- 4 Replace the battery vent caps.
- 5 Connect the battery charger to a grounded AC circuit.
- 6 Turn the battery charger on.
- 7 The charger will indicate when the battery is fully charged.
- 8 Check the battery acid level when the charging cycle is complete. Replenish with distilled water to the bottom of the fill tube. Do not overfill.

Dry Battery Filling and Charging Instructions

- 1 Remove the battery vent caps and permanently remove the plastic seal from the battery vent openings.
- 2 Fill each cell with battery acid (electrolyte) until the level is sufficient to cover the plates.

Do not fill to maximum level until the battery charge cycle is complete. Overfilling can cause the battery acid to overflow during charging. Neutralize battery acid spills with baking soda and water.

- 3 Install the battery vent caps.
- 4 Charge the battery.
- 5 Check the battery acid level when the charging cycle is complete. Replenish with distilled water to the bottom of the fill tube. Do not overfill.

Transport Instructions



Observe and Obey:

- Common sense and planning must be applied to control the movement of the machine when lifting it with a crane.
- The transport vehicle must be parked on a level surface.
- The transport vehicle must be secured to prevent rolling while the machine is being loaded.
- Be sure the vehicle capacity, loading surfaces and chains or straps are sufficient to withstand the machine weight. See serial plate.
- The machine must be on a level surface or secured before releasing the brakes.

Securing to Truck or Trailer for Transit

Always chock machine wheels in preparation for transport.

Use tie-down points on chassis for anchoring down to transport surface.

Use chains or straps of ample load capacity.

Turn key switch to the OFF position and remove key before transporting.

Inspect entire machine for loose or unsecured items.

Brake Release Operation

- 1 Chock the wheels to prevent the machine from rolling.
- 2 Be sure the winch line is properly secured to the drive chassis tie points and the path is clear of all obstructions.
- 3 Turn the brake release knob counterclockwise to open the brake valve.
- 4 Pump the brake release pump knob.

After the machine is loaded:

- 1 Chock the wheels to prevent the machine from rolling.
- 2 Turn the brake release knob clockwise to reset the brakes.

Towing the Genie GS-2668 DC or the GS-3268DC is not recommended. If the machine must be towed, do not exceed 2 mph / 3.2 km/h.

Decals

Decal Inspection

Use the pictures on the next page to verify that all decals are legible and in place.

Below is a numerical list with quantities and descriptions.

Part No.	Description	Quantity	Part No.	Description	Quantity
25994	Caution - Component Damage	1	52070	Notice - Tire Specifications	4
28157	Label - Dexron	1	52431	Label, Ground Control Panel	1
28164	Notice - Hazardous Materials	1	52475	Label - Transport Tie-down	4
28171	Label - No Smoking	1	52494	Caution - Crushing Hazard - Rails	1
28174	Label - Power to Platform, 230V	3	52673	Notice - Max Side Force, ANSI & CSA - GS-2668 RT & DC	1
28175	Caution - Compartment Access	1	52674	Notice - Max Side Force, CE - GS-2668 RT & DC	1
28176	Notice - Missing Manuals	1	52682	Notice - Max Capacity 1000 lbs / 454 kg - GS-3268 RT & DC	1
28235	Label - Power to Platform, 115V	3	52802	Notice - Max Side Force, ANSI & CSA - GS-3268 RT & DC	1
28236	Warning - Failure To Read . . .	1	52803	Notice - Max Side Force, CE - GS-3268 RT & DC	1
31060	Danger - Do Not Alter Limit Switch	2	52864	Platform Control Panel	1
31508	Notice - Power to Charger	1	52966	Cosmetic - 4 x 2	2
40434	Label - Lanyard Anchorage	2	65052	Label - Fault Codes	1
43091	Danger - General Safety Rules	2	62061	Cosmetic - Genie GS-2668 DC	2
43617	Danger - Tip-over Hazard	1	62062	Cosmetic - Genie GS-3268 DC	2
43618	Label - Directional Arrows	1	72970	Notice - Charger Instructions	1
43619	Label - Safety Arm	1	82239	Label - Latch	2
43658	Label - Power to Charger - 230V	1	82261	Ground Control Panel	1
43696	Danger - Electrocutation Hazard	2	82263	Notice - Operating Instructions, Ground	1
44220	Danger/Notice - Brake Release Safety & Operating Instructions	1	82270	Notice - Battery Connection Diagram	1
44255	Danger - Crushing Hazard	4	82273	Notice - Operating Instructions - Platform	1
44736	Danger - Tilt Alarm	1			
44980	Label - Power to Charger - 115V	1			
48727	Danger - Battery Safety	1			
49911	Notice - Max Capacity 1250 lbs / 590 kg - GS-2668 RT & DC	1			

DECALS

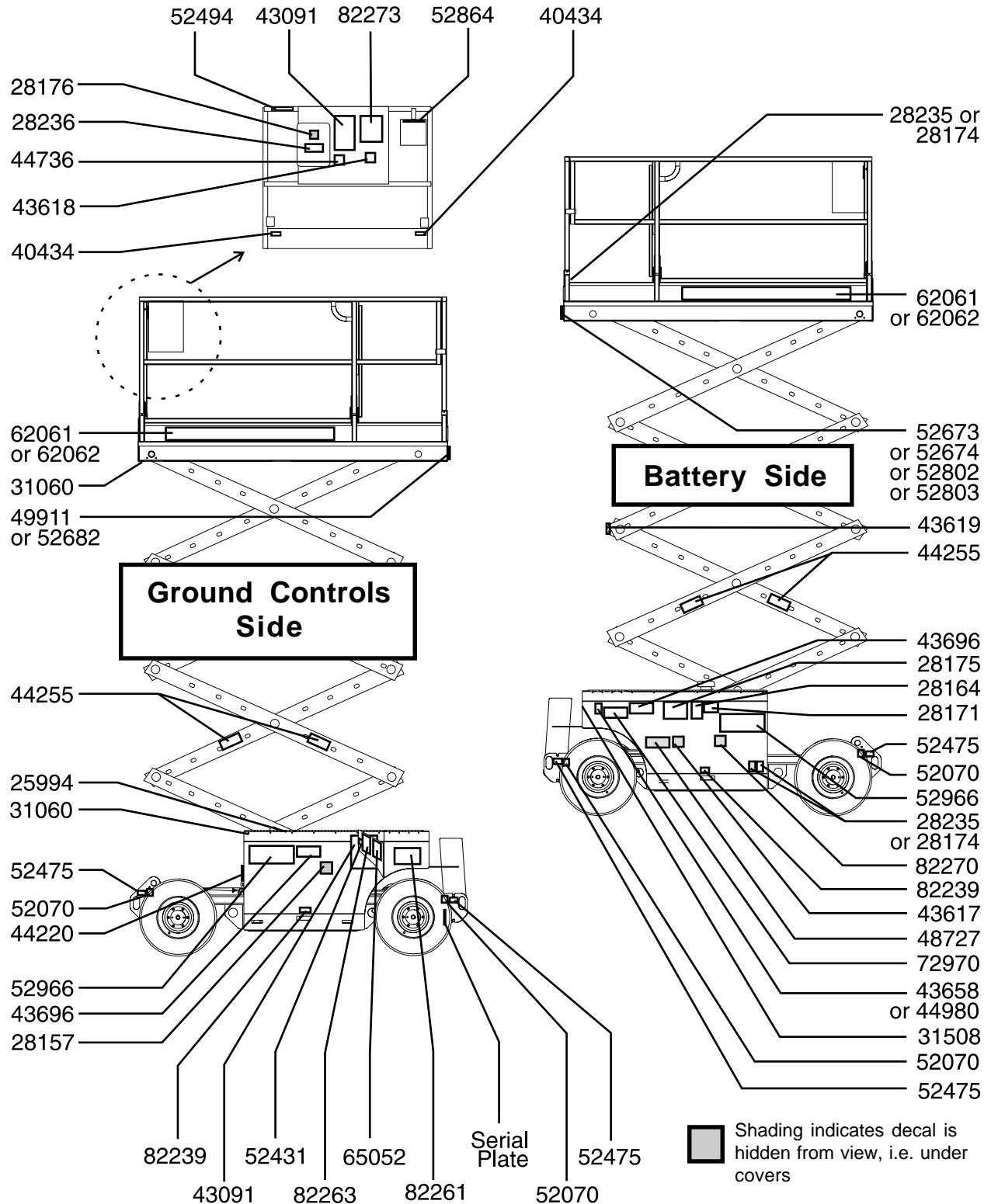

Specifications

Model	GS-2668 DC	
Height, working maximum	32 ft	9.9 m
Height, platform maximum	26 ft	7.9 m
Height, stowed maximum Rails up	92 in	2.34 m
Height, stowed maximum Rails lowered	64 ¹ / ₂ in	1.64 m
Height, stowed maximum Rails off	46 ¹ / ₂ in	1.18 m
Height, guard rails	40 in	1.02 m
Width	68 in	1.73 m
Length, platform retracted	105 in	2.67 m
Length, platform extended	165 in	4.2 m
Maximum load capacity	1250 lbs	567 kg
Wheelbase	73 in	1.85 m
Turning radius (outside)	145 in	3.68 m
Turning radius (inside)	60 in	1.52 m
Ground clearance	7 ¹ / ₂ in	19 cm
Weight (Machine weights vary with option configurations)	See Serial Plate	
Gradeability	30%	
Airborne noise emissions Maximum sound level at normal operating workstations (A-weighted)	>80 dB	
Power source	8 Batteries, 225AH	
Controls	Proportional	
AC outlet in platform	standard	

Maximum hydraulic pressure (functions)	3500 psi	241 bar
---	----------	---------

Tires size	23x10.5x360	
------------	-------------	--

Platform dimensions

Platform length x width	99 in x 61in	2.5 x 1.55 m
-------------------------	--------------	--------------

Platform extension length	60 in	1.52 m
---------------------------	-------	--------

Drive speeds

Stowed, maximum	3.3 mph	5.3 km/h
-----------------	---------	----------

Platform raised, maximum	0.5 mph	0.8 km/h
	40 ft/54.6 sec	12.2 m/54.6 sec

Floor Loading Information

GVW + Rated Load	8100 lbs	3674 kg
------------------	----------	---------

Axle load, maximum	4120 lbs	1868 kg
--------------------	----------	---------

Wheel load, maximum	2060 lbs	934 kg
---------------------	----------	--------

Localized pressure per tire	86 psi	6.04 kg/cm ² 592 kPa
-----------------------------	--------	------------------------------------

Occupied pressure	158 psf	7.56 kPa
-------------------	---------	----------

Note: Floor loading information is approximate and does not incorporate different option configurations. It should be used only with adequate safety factors.

Continuous improvement of our products is a Genie policy.
Product specifications are subject to change without notice or obligation.

SPECIFICATIONS

Model	GS-3268 DC	
Height, working maximum	38 ft	11.8 m
Height, platform maximum	32 ft	9.8 m
Height, stowed maximum Rails up	97 in	2.46 m
Height, stowed maximum Rails lowered	69 ¹ / ₂ in	1.77 m
Height, stowed maximum Rails off	51 ¹ / ₂ in	1.31 m
Height, guard rails	40 in	1.02 m
Width	68 in	1.73 m
Length, platform retracted	105 in	2.67 m
Length, platform extended	165 in	4.19 m
Maximum load capacity	1000 lbs	454 kg
Wheelbase	73 in	1.85 m
Turning radius (outside)	145 in	3.68 m
Turning radius (inside)	60 in	1.52 m
Ground clearance	7 ¹ / ₂ in	19 cm
Weight (Machine weights vary with option configurations)	See Serial Plate	
Gradeability	25%	
Airborne noise emissions Maximum sound level at normal operating workstations (A-weighted)	>80 dB	
Power source	8 Batteries, 225AH	
Controls	Proportional	
AC outlet in platform	standard	

Maximum hydraulic pressure (functions)	3500 psi	241 bar
---	----------	---------

Tires size	23x10.5x360	
------------	-------------	--

Platform dimensions

Platform length x width	99 in x 61 in	2.5 x 1.5 m
-------------------------	---------------	-------------

Platform extension length	60 in	1.5 m
---------------------------	-------	-------

Drive speeds

Stowed, maximum	3.3 mph	5.3 km/h
-----------------	---------	----------

Platform raised, maximum	0.5 mph	0.8 km/h
	40 ft/54.6 sec	12.2 m/54.6 sec

Floor Loading Information

GVW + Rated Load	8580 lbs	3892 kg
------------------	----------	---------

Axle load, maximum	3940 lbs	1787 kg
--------------------	----------	---------

Wheel load, maximum	1970 lbs	893 kg
---------------------	----------	--------

Localized pressure per tire	82 psi	5.78 kg/cm ² 566 kPa
-----------------------------	--------	------------------------------------

Occupied pressure	173 psf	8.29 kPa
-------------------	---------	----------

Note: Floor loading information is approximate and does not incorporate different option configurations. It should be used only with adequate safety factors.

Genie Holland
Phone +31 70 51 78836
Fax +31 70 51 13993

Genie Scandinavia
Phone +46 31 3409612
Fax +46 31 3409613

Genie France
Phone +33 (0)2 37 26 09 99
Fax +33 (0)2 37 26 09 98

Genie Ibérica
Phone +34 93 579 5042
Fax +34 93 579 5059

Genie Germany
Phone +49 (0)4202 88520
Fax +49 (0)4202 8852-20

Genie U.K.
Phone +44 (0)1476 584333
Fax +44 (0)1476 584334

Genie Mexico City
Phone +52 5 653 03 84
Fax +52 5 664 40 16

Genie North America
Phone 425.881.1800
Toll Free USA and Canada
800.536.1800
Fax 425.883.3475

Genie Australia Pty Ltd.
Phone +61 7 3375 1660
Fax +61 7 3375 1002

Genie China
Phone +86 21 53852570
Fax +86 21 53852569

Genie Malaysia
Phone +60 4 228 1235
Fax +60 4 226 6872

Genie Japan
Phone +81 3 3453 6082
Fax +81 3 3453 6083

Genie Korea
Phone +82 2 558 7267
Fax +82 2 558 3910

Genie Africa
Phone +27 11 455 0373
Fax +27 11 455 0355

Genie Latin America
Phone +55 11 4055 2499
Fax +55 11 4043 1661

Distributed By: