

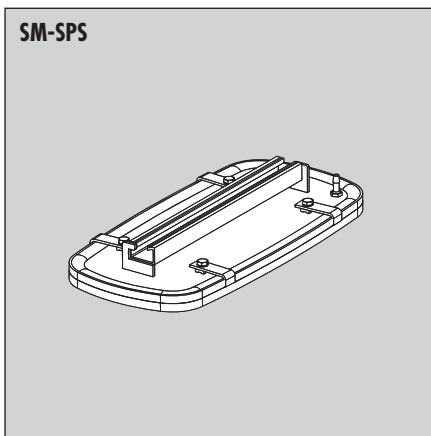

SM-400

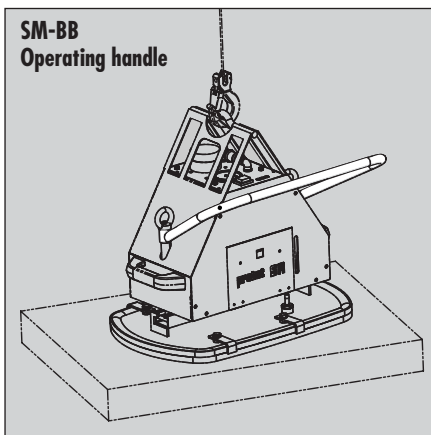

SM-SPS



SM-BB
Operating handle

STONEMAGNET SM-400 Vacuum Lifting Device

Handy, powerful and cordless vacuum lifting device for laying of dense stone slabs, concrete elements, pipes and similar. Can be used on all kind of lifting equipment.

- ▶ Specially designed and equipped for heavy duty work on the construction site.
- ▶ For special purposes, there are different suction plates available, which can be attached to the SM easily.

Standard Specifications:

- ▶ Robust and compact main body, with integrated suspension for crane hook and quick change device for the suction plate.
- ▶ Powered by rechargeable, exchangeable 12 V battery. Power saving control system makes battery lasting for one whole working day. Battery can be exchanged within seconds. Battery charge indicator. Battery charger not included.

▶ Security features: Flashing light to warn on insufficient low pressure, automatic control system to start the vacuum pump after loss of pressure, manometer, high volume vacuum storage tank.

▶ Standard suction plate 580 x 280 mm with special seal system, exchangeable within seconds without the use of glue or tools. No damage to the seal when setting on sharp edges for long time (no "supports" necessary).

Special features:

The SM is equipped with 2 vacuum-pumps as standard. When handling dense products, only one pump is used. On slightly porous material, or when quick cycle time is required, the second pump can be switched on by the TURBO switch.

Type	Description	Drive	Dead Weight kg (lbs)	Order-Number
SM-400	Basic device, without suction plate	by 12 V battery	28 (60)	5272.0002

Suction Plates

Type	Suction Plate Dimension mm (in)	Carrying Capacity* kg (lbs)	Dead Weight kg (lbs)	Order-Number
SM-SPS-90-30/20	approx. 300 x 200 (11¾" x 7¾")	90 (200)	5,0 (10)	4272.0009
SM-SPS-200-58/28	approx. 580 x 280 (22¾" x 11")	200 (440)	9,0 (20)	4272.0001
SM-SPS-400-75/27	approx. 750 x 270 (29½" x 10½")	400 (880)	10,0 (25)	4272.0002
ED-SPS-90	Highly wear-resistant replacement seal: Easy to attach without glueing.			4250.0023
ED-SPS-200				4272.0004
ED-SPS-400				4272.0005
Special Suction Plates:				
SM-SPS-HP-100-90/9	900 x 90 (35½" x 3½")	100 (220)	7,0 (15)	4272.0115
SM-SPS-160-90/12	900 x 120 (35½" x 4¾")	160 (355)	7,0 (15)	4272.0047
SM-SPS-150-41/22	410 x 220 (16" x 8½")	150 (330)	5,0 (10)	4272.0018
SM-SPS-150-80/14	800 x 140 (31½" x 5½")	150 (330)	7,0 (15)	4272.0013
SM-SPS-120-80/12	800 x 120 (31½" x 4¾")	120 (265)	6,0 (13)	4272.0043

* Value at 500 mbar low pressure

Accessories

Type	Description	Order-Number
Battery-12V/26Ah	Spare storage battery, 24 Ah, 12 V	2420.0008
LG Battery charging device 220 V / 12 V	Battery charging device w/overload protection and charging current limiting. Housing is water and dust-proof.	2420.0016
SM-BB Operating handle	(also for retrofitting)	4272.0063

Special suction plates, for example for pipes, on request.

Ⓛ Durable surface protection by galvanizing